



New Hampshire Fish and Game Department

61 - 6/17/26

11 Hazen Drive, Concord, NH 03301-6500
(603) 271-3421
FAX: (603) 271-5829

www.wildlife.nh.gov
Email: info@wildlife.nh.gov
TDD Access: Relay NH 1-800-735-2964

Stephanie L. Simek, Ph.D.
Executive Director

May 12, 2026

Her Excellency, Governor Kelly A. Ayotte
And the Honorable Council
State House
Concord, New Hampshire 03301

REQUESTED ACTION

Pursuant to MOP 150, VII (C), authorize the New Hampshire Fish and Game Department to purchase three medium-duty flatbed trucks from New England Kenworth (VC#158735) in the amount of \$343,032 effective upon Governor and Council approval through June 30, 2026. 100% Transfer from Other Agency (Volkswagen Mitigation Funds).

Funding is available in account, Administrative Support-Fleet Management, as follows:

		<u>FY 2026</u>
03-75-75-750520-21190000-030-500320	Equipment	\$343,032

EXPLANATION

The New Hampshire Fish and Game Department respectfully requests approval to award the contract for three medium-duty flatbed fish stocking trucks. Working with the Department of Administrative Services, the Department issued RFB 125-26, which received six bids. New England Kenworth submitted the lowest responsible bid.

These trucks are critical to transporting live fish from state hatcheries to waterbodies throughout New Hampshire. Their specialized tanks and oxygenation systems ensure safe, efficient stocking that supports the State's fisheries and the recreational opportunities enjoyed by residents statewide.

The competitive bid resulted in cost savings of \$23,118.00 compared to the original quote.

We respectfully request your approval to proceed with this purchase.

Respectfully Submitted,

Stephanie L. Simek Ph.D.
Executive Director

Kathy Ann LaBonte, Chief
Business Division



State of New Hampshire Purchase Order

**PURCHASE ORDER NUMBER
6004212**

This number must appear on all invoices, packages, cartons, bills of lading, and packing slips.

**Date: 05/01/2026
Status: DRAFT
Ship Via:
FOB: Destination
Freight Terms: Vendor Paid
Terms: Net 30
Due Days: 30**

**Bill To: FISH AND GAME COMMISSION
11 HAZEN DR
CONCORD NH 03301-6500**

**NEW ENGLAND KENWORTH
24 HALL ST
CONCORD NH 03302-1866**

**Ship To:
FISH AND GAME COMMISSION
11 HAZEN DR
CONCORD NH 03301**

Phone: 603 226 2000

AGENCY CONTACT: ALEX SITEK 603-271-1745

**Vendor #: 158735
Contact: MaryBeth Alosa**

In accordance with RFB 125-26

LINE	QTY	UOM	DESCRIPTION	UNIT PRICE	EXTENDED PRICE
Deliver on or before October 31, 2026 unless specified by line					
1	1.00	EA	MD TRUCK WITH 20' FLATBED MD TRUCK WITH 20' FLATBED	126,942.00000	126,942.00
2	2.00	EA	MD TRUCKS WITH 16' FLATBED MD TRUCKS WITH 16' FLATBED	108,045.00000	216,090.00
Purchase Order Summary					
				Goods Total:	\$343,032.00
				Order Total:	\$343,032.00

**Buyer: Lincoln Adams
Phone: 603-271-0580
Process Level: 07500**

Total Amount: \$343,032.00

1. The State of New Hampshire engages the firm or individual ("the Vendor") to perform the services and/or sale of goods, described in the attached State Proposal and the Vendor's proposal, bid or quotation, any of which are incorporated herein by reference.

2. COMPLIANCE BY VENDOR WITH LAWS AND REGULATIONS. In connection with the performance of this agreement, the Vendor shall comply with all statutes, laws, regulations, and orders of federal, state, county or municipal authorities which shall impose any obligation or duty upon the Vendor, including, but not limited to civil rights and equal opportunity laws. In addition, the Vendor shall comply with all applicable copyright laws.

3. TERM. The contract and all obligations of the parties thereunder, shall become effective on a specified date and shall be completed in their entirety prior to a specified date. Any work undertaken by the Vendor prior to the effective date shall be at his sole risk and, in the event that the contract shall not become effective, the State shall be under no obligation to reimburse the Vendor for any such work.

4. CONTRACT PRICE. The contract price, a payment schedule and a maximum limitation of price shall be as specified by the proposal or bid invitation and the Vendor's response. All payments shall be conditioned upon receipt, and approval by the State, of appropriate vouchers and upon satisfactory performance by the Vendor, as determined by the State. The payment by the State of the Contract Price shall constitute complete reimbursement to the Vendor for all expenses of any nature incurred by the Vendor in the performance by the contractor and complete payment for the Services. The State shall have no other liability to the Vendor.

5. DELIVERY. If the Vendor fails to furnish items and/or services in accordance with all requirements, including delivery, the state may repurchase similar items from any other source without competitive process, and the original Vendor may be liable to the state for any excess costs.

If a Vendor is unable to complete delivery by the date specified, he must contact the using branch and or agency. However, the branch and or agency is not required to accept a delay to the original delivery date. All deliveries are subject to inspection and receiving procedure rules as established by the State of New Hampshire. Deliveries are not considered accepted until compliance with these rules has been established. State personnel signatures on shipping documents shall signify only the receipt of shipment.

6. INVOICING. All invoices must be in triplicate showing Order Number, Unit and Extension Prices and discounts allowed. A separate invoice shall be submitted for each order. Unless otherwise noted on the proposal or purchase order, payment will not be due until thirty(30) days after all services have been completed, or all items have been delivered, inspected and accepted or the invoice has been received, whichever is later.

7. PERSONNEL.

7.1. The Vendor shall disclose in writing the names of all owners (5% or more), directors, officers, employees, agents or subcontractors who are also officials or employees of the State of New Hampshire. Any change in this information shall be reported in writing within fifteen (15) days of their occurrence.

7.2. The person signing this agreement on behalf of the State, or his or her delegee ("Contracting Officer") shall be the State's representative for purposes of this agreement. In the event of any dispute concerning the interpretation of this agreement, the Contracting Officer's decision shall be final.

8. EVENT OF DEFAULT; REMEDIES.

8.1. Any one or more of the following acts or omissions of the Vendor shall constitute an event of default hereunder ("Events of Default").

8.1.1. failure to deliver the goods or services satisfactorily or on schedule; or

8.1.2. failure to submit any report required hereunder; or

8.1.3. failure to perform any of the other covenants and conditions of this agreement.

8.2. Upon the occurrence of any Event of Default, the State may take any one, or more, or all, of the following actions:

8.2.1. give the Vendor a written notice specifying the Event of Default and requiring it to be remedied within, in the absence of a greater or lesser specification of time, thirty(30) days from the date of the notice; and if the Event of Default is not timely remedied, terminate this agreement, effective two (2) days after giving the Vendor notice of termination; and

8.2.2. give the Vendor a written notice specifying the Event of Default and suspending all payments to be made under this agreement and ordering that the portion of the Contract Price, which would otherwise accrue to the Vendor during the period from the date of such notice until such time as the State determines that the Vendor has cured the Event of Default, shall never be paid to the Vendor; and

8.2.3. set off against any other obligation the State may owe to the Vendor any damages the State suffers by reason of any Event of Default; and

8.2.4. treat the agreement as breached and pursue any of its remedies at law or in equity, or both.

9. WAIVER OF BREACH. No failure by the State to enforce any provisions hereof after any Event of Default shall be deemed a waiver of its rights with regard to that Event, or any subsequent Event. No express failure of any Event of Default shall be deemed a waiver of any provision hereof. No such failure or waiver shall be deemed a waiver of the right of the State to enforce each and all of the provisions hereof regarding any further or other default on the part of the Vendor.

10. VENDOR'S RELATION TO THE STATE. In the performance of this agreement the Vendor is in all respects an independent contractor, and is neither an agent nor an employee of the State. Neither the Vendor nor any of its officers, employees, agents or members shall have authority to bind the State nor are they entitled to any of the benefits, workmen's compensation or emoluments provided by the State to its employees.

11. ASSIGNMENT AND SUBCONTRACTS. The Vendor shall not assign, or otherwise transfer any interest in this agreement without the prior written consent of the State. No work required by this contract shall be subcontracted without the prior written consent of the State.

12. INDEMNIFICATION. The Vendor shall defend, indemnify and hold harmless the State, its officers and employees, from and against any and all losses suffered by the State, its officers and employees, and any and all claims, liabilities or penalties asserted against the state, its officers and employees, by or on behalf of any person, on account of, based on, resulting from, arising out of (or which may be claimed to arise out of) the acts or omissions of the Vendor. Notwithstanding the foregoing, nothing herein contained shall be deemed to constitute a waiver of the sovereign immunity of the State, which immunity is hereby reserved to the State. This covenant shall survive the termination of this agreement.

12.1. PATENT PROTECTION. The Vendor agrees to indemnify and defend the State of New Hampshire from alleged and actual patent infringements and further agrees to hold the State of New Hampshire harmless from any liability arising under RSA 382-A:2-312(3). (Uniform Commercial Code).

13. TOXIC SUBSTANCES. In compliance with RSA 277-A known as the Workers Right to Know Act, the Vendor shall provide Material Safety Data Sheets with the delivery of any and all products covered by said law.

14. NOTICE. Any notice by a party hereto to the other party shall be deemed to have been duly delivered or given at the time of mailing by certified mail, postage prepaid, in a United States Post Office addressed to the parties at the addresses given below.

15. AMENDMENT. This agreement may be amended, waived or discharged only by an instrument in writing signed by the parties hereto.

16. CONSTRUCTION OF AGREEMENT AND TERMS. This agreement shall be construed in accordance with the laws of the State of New Hampshire, and is binding upon and inures to the benefit of the parties and their respective successors and assigns.

17. ADDITIONAL PROVISIONS. The additional provisions (if any) have been set forth as Exhibit "A" hereto.

18. ENTIRE AGREEMENT. This agreement, which may be executed in a number of counterparts, each of which shall be deemed an original, constitutes the entire agreement and understanding between the parties, and supersedes all prior agreements and understandings relating hereto.



Division of Procurement Support Services
Bureau of Purchase Property

Gary S. Lunetta
Director
(603) 271-2201

Bid Summary

Bid Description	Medium Duty Trucks (33,000 Lb Gross Combination Weight)	Agency	NH F&G
Bid #	125-26	RQ #	256472
Agent Name	Lincoln Adams	Bid Closing	4/23/2026 @ 11:00 AM

Qty	UOM	Product Description	New England Kenworth		Rochester Truck		New England Kenworth		New England Kenworth		One Nation Distribution, LLC		ATG Manchester LLC	
			Unit Cost	Extended Cost	Unit Cost	Extended Cost	Unit Cost	Extended Cost	Unit Cost	Extended Cost	Unit Cost	Extended Cost	Unit Cost	Extended Cost
2	EA	Medium Duty Truck w/ 16' Flatbed (33,000 lb. GVWR)	\$108,045.00	\$216,090.00	\$110,216.00	\$220,432.00	\$114,912.00	\$229,824.00	\$114,912.00	\$229,824.00	\$152,989.00	\$305,978.00	\$117,950.00	\$235,900.00
1	EA	Medium Duty Truck w/ 20' Flatbed (33,000 lb. GVWR)	\$126,942.00	\$126,942.00	\$122,704.00	\$122,704.00	\$134,606.00	\$134,606.00	\$137,930.00	\$137,930.00	\$182,989.00	\$182,989.00	No Bid	No Bid
		Total		\$343,032.00		\$343,136.00		\$364,430.00		\$367,754.00		\$488,967.00		\$235,900.00



**NEW HAMPSHIRE DEPARTMENT OF ADMINISTRATIVE SERVICES
DIVISION OF PROCUREMENT AND SUPPORT SERVICES**

**REQUEST FOR BID
FOR
MEDIUM DUTY TRUCKS (33,000 LB GROSS COMBINATION WEIGHT)**

125-26

DUE DATE: 4/14/2026 11:00 AM (EASTERN TIME)

Table of Contents

1. PURPOSE: 3

2. INSTRUCTIONS TO VENDOR: 3

3. BID SUBMITTAL:..... 3

4. BID INQUIRIES: 3

5. BID DUE DATE:..... 3

6. ADDENDA: 3

7. TIMELINE: 3

8. GOVERNING TERMS AND CONDITIONS: 4

9. NON-EXCLUSIVE CONTRACT: 4

10. PUBLIC DISCLOSURE OF BID OR PROPOSAL SUBMISSIONS: 4

11. VENDOR CERTIFICATIONS:..... 5

12. VENDOR RESPONSIBILITY:..... 5

13. WARRANTY REQUIREMENTS:..... 5

14. BID PRICES: 5

15. AUDITS AND ACCOUNTING:..... 6

16. terms of PAYMENT: 6

17. INVOICING:..... 6

18. AWARD:..... 6

19. BID RESULTS: 6

20. TERMINATION:..... 6

21. F.O.B.: 6

22. RETURNED GOODS:..... 7

23. SPECIFICATION COMPLIANCE:..... 7

24. SPECIFICATIONS:..... 7

25. ENVIRONMENTALLY FRIENDLY PRODUCTS:..... 8

26. OFFER: 8

27. DELIVERY TIME:..... 8

28. VENDOR CONTACT INFORMATION: 8

29. Note: To be considered, BID TRANSMITTAL LETTER shall be signed in the space provided. 9

30. The Bid Opening is open to the public online at the following:..... 9

STATE OF NEW HAMPSHIRE TRANSMITTAL LETTER 10

GENERAL TERMS AND CONDITIONS 11

CONTRACT TERMS AND CONDITIONS 12

1. **PURPOSE:**

1.1. The purpose of this bid invitation is to establish a contract in the form of a purchase order, for supplying the State of New Hampshire with the item(s) indicated in the "Offer" section of this bid invitation, in accordance with the requirements of this bid invitation and any resulting order. This shall be a one-time order with delivery required to the location indicated in the F.O.B. section of this bid invitation.

2. **INSTRUCTIONS TO VENDOR:**

2.1. Read the entire bid invitation prior to filling it out. Complete the pricing information in the "Offer" section (detailed information on how to fill out the pricing information can be found in the "Offer" section); complete the "Vendor Contact Information" section; and finally, fill out, and sign the transmittal letter.

3. **BID SUBMITTAL:**

3.1. All bids shall be submitted on this form, or an exact copy shall be typed or clearly printed in ink and shall be received on or before the date and time specified in paragraph 7 of this bid under "Bid closing". Interested parties may submit a bid to the State of New Hampshire Bureau of Purchase and Property by email to NH.Purchasing@DAS.NH.Gov. All bids shall be clearly marked with bid number, date due and purchasing agent's name.

3.2. IF YOU ARE EXPERIENCING DIFFICULTIES EMAILING YOUR BID OR YOU WISH TO VERIFY THAT YOUR BID RESPONSE HAS BEEN RECEIVED, PLEASE CALL (603) 271-2201.

4. **BID INQUIRIES:**

4.1. Any questions, clarifications, and/or requested changes shall be submitted by an individual authorized to commit their organization to the Terms and Conditions of this bid and shall be received in writing at the Bureau of Purchase and Property no later than 4:00 PM on the date listed in paragraph 7. Questions shall not be submitted to anyone other than the Purchasing Agent or his/her representative. Bidders that submit questions verbally or in writing to any other State entity or State personnel shall be found in violation of this part and may be found non-compliant.

4.2. Questions shall be submitted by email to Lincoln Adams at Lincoln.J.Adams@DAS.NH.Gov.

4.3. Submissions shall clearly identify the bid Number, the Vendor's name and address and the name of the person submitting the question.

5. **BID DUE DATE:**

5.1. All bid submissions shall be received at the Bureau of Purchase and Property no later than the date and time shown on the transmittal letter of this bid. Submissions received after the date and time specified shall be marked as "Late" and shall not be considered in the evaluation process.

5.2. All bid submissions shall be treated as firm offers to remain valid for acceptance for a period of one hundred eighty (180) days from the bid due date. The transmittal of a vendor's response or bid submission to any State agency or office other than the Department of Administrative Services (DAS), Bureau of Purchase and Property may be grounds for disqualification.

6. **ADDENDA:**

6.1. In the event it becomes necessary to add to or revise any part of this bid prior to the scheduled submittal date, the NH Bureau of Purchase and Property shall post on our web site any Addenda. Before your submission and periodically prior to the RFB closing, check the site for any addenda or other materials that may have been issued affecting the bid. The web site address is <https://das.nh.gov/Purchasing/vendorresources.aspx>.

7. **TIMELINE:**

7.1. The timeline below is provided as a general guideline and is subject to change. Unless stated otherwise, consider the dates below a "no later than" date.

Bid Solicitation distributed on or by:	3/31/2026
Last day for questions, clarifications, and/or requested changes to bid:	4/9/2026
States response to questions, clarifications, and/or requested changes to bid:	4/13/2026
Bid Closing (Eastern Time):	4/14/2026 11:00 AM

8. **GOVERNING TERMS AND CONDITIONS:**

- 8.1. A responding bid that has been completed and signed by your representative shall constitute your company's acceptance of all State of New Hampshire terms and conditions and shall legally obligate your company to these terms and conditions.
- 8.2. A signed response further signifies that from the time the bid is published (bid solicitation date and time) until a contract is awarded, no bidder shall offer or give, directly or indirectly, any gift, expense reimbursement, or honorarium, as defined by RSA 15-B, to any elected official, public official, public employee, constitutional official, or family member of any such official or employee who shall select, evaluate, or award the RFB.
- 8.3. Furthermore, a signed response signifies that any terms and/or conditions that may be or have been submitted by the Vendor are specifically null and void and are not a part of this bid invitation or any awarded purchase order, even if said terms and/or conditions contain language to the contrary.
- 8.4. CHAPTER ADM 600 PROCUREMENT AND PROPERTY RULES APPLY TO AND ARE MADE A PART HEREOF.

9. **NON-EXCLUSIVE CONTRACT:**

- 9.1. Any resulting Contract from this RFB will be a non-exclusive Contract. The State reserves the right, at its discretion, to retain other Contractors to provide any of the Services or Deliverables identified under this procurement or make an award by item, part or portion of an item, group of items, or total Proposal.

10. **PUBLIC DISCLOSURE OF BID OR PROPOSAL SUBMISSIONS:**

- 10.1. Generally, the full contents of any proposal (including all materials submitted in connection with it, such as attachments, exhibits, addenda, and vendor presentations) become public information upon completion of final contract or purchase order negotiations with the selected vendor. Certain information concerning proposals, including but not limited to scoring, is generally available to the public even before this time, in accordance with the provisions of NH RSA 21-G:37.
- 10.2. Confidential, commercial, or financial information may be exempt from public disclosure under RSA 91-A:5, IV. Any and all information contained in or connected to a bid or proposal that a Bidder considers confidential shall be clearly designated in the following manner:
- 10.3. **If the Bidder considers any portion of a submission confidential, they shall provide a separate copy of the full and complete document, fully redacting those portions by blacking them out and shall note on the applicable page or pages of the document that the redacted portion or portions are stamped or otherwise marked with the notation "confidential."** Use of any other term or method, such as stating that a document or portion thereof is "proprietary", "not for public use", or "for client's use only", is *not* acceptable. In addition to providing an additional fully redacted copy of the bid submission to the person listed as the point of contact on Page one (1) of this document, the identified information considered to be confidential must be accompanied by a separate letter stating the rationale for each item designated as confidential. In other words, the letter must specifically state why and under what legal authority each redaction has been made. Submissions which do not conform to these instructions by failing to include a redacted copy (if required), by failing to include a letter specifying the rationale for each redaction, by failing to designate redactions in the manner required by these instructions, or by including redactions which are contrary to these instructions or operative law may be rejected by the State as not conforming to the requirements of the bid or proposal. Marking or designating an entire proposal, attachment, or section as confidential shall neither be accepted nor honored by the State. Marking an entire bid, proposal, attachment or full sections thereof confidential without taking into consideration the public's right to know shall neither be accepted nor honored by the State.
- 10.4. Notwithstanding any provision of this request for submission to the contrary, proposed pricing shall be subject to public disclosure REGARDLESS of whether or not marked as confidential.
- 10.5. If a request is made to the State by any person or entity to view or receive copies of any portion of a proposal, the State will assess what information it believes is subject to release; notify the Bidder that the request has been made; indicate what, if any, portions of the proposal or related material shall be released; and notify the Bidder of the date it plans to release the materials. To halt the release of information by the State, a Bidder must initiate and provide to the State, prior to the date specified in the notice, a court action in the Superior Court of the State of New Hampshire, at its sole expense, seeking to enjoin the release of the requested information.
- 10.6. By submitting a proposal, Bidders acknowledge and agree that:

- 10.6.1. The State may disclose any and all portions of the proposal or related materials which are not marked as confidential and/or which have not been specifically explained in the letter to the person identified as the point of contact for this RFB;
- 10.6.2. The State is not obligated to comply with a Bidder's designations regarding confidentiality and must conduct an independent analysis to assess the confidentiality of the information submitted in your proposal; and
- 10.6.3. The State may, unless otherwise prohibited by court order, release the information on the date specified in the notice described above without any liability to a Bidder.

11. VENDOR CERTIFICATIONS:

- 11.1. All Vendors shall be duly registered as a vendor authorized to conduct business in the State of New Hampshire.
- 11.2. STATE OF NEW HAMPSHIRE VENDOR APPLICATION: Prior to bid award, Vendors shall have a completed Vendor Application Package on file with the NH Bureau of Purchase and Property. See the following website for information on obtaining and filing the required forms (no fee):
<https://das.nh.gov/purchasing/vendorresources.aspx>.

12. VENDOR RESPONSIBILITY:

- 12.1. The successful Vendor shall be solely responsible for meeting all terms and conditions specified in the bid, and any resulting contract. It is a prospective Vendor's responsibility to access our website to determine any bid invitation under which they wish to participate. It is also the Vendor(s)'s responsibility to access our website for any posted addendum.
- 12.2. All State of New Hampshire bid invitations and addenda to these bid invitations are advertised on our website at: <https://das.nh.gov/purchasing/vendorresources.aspx>.
- 12.3. The website is updated several times per day; it is the responsibility of the prospective Vendor(s) to access the website frequently to ensure no bidding opportunity or addenda is overlooked.
- 12.4. It is the prospective Vendor's responsibility to forward a signed copy (if the form has a signature block) of any addenda to the Bureau of Purchase and Property with the bid response.
- 12.5. In preparation of your bid response, you shall:
 - 12.5.1. Complete the pricing information in the "Offer" section; and
 - 12.5.2. You may include quote separately, but the **OFFER SECTION MUST** be completed for compliant acceptance.
 - 12.5.3. Complete all other required information on your offer (if applicable); and
 - 12.5.4. Complete the "Vendor Contact Information" section; and
 - 12.5.5. Complete the company information on the "Transmittal Letter" page, and sign under penalty of unsworn falsification in the space provided on that page.

13. WARRANTY REQUIREMENTS:

- 13.1. Successful Vendor shall be required to warranty all of the equipment/item awarded to Vendor for a period of not less than one (1) year or the manufacturer's standard period of time, whichever is greater, from the date the items are received, inspected and accepted by the State of New Hampshire. The warranty shall cover 100% of all parts, shipping, labor, travel, lodging and expenses.

14. BID PRICES:

- 14.1. Bid prices shall remain firm for the entire contract period and shall be in US dollars and **shall include delivery and all other costs** required by this bid invitation. Special charges, surcharges (including credit card transaction fees), or fuel charges of any kind (by whatever name) **may not be added on at any time**. Any and all charges **shall be built into your bid price** at the time of the bid. Unless otherwise specified, prices shall be F.O.B. DESTINATION, (included in the price bid), which means delivered to a state agency's receiving dock or other designated point as specified in this contract or subsequent purchase orders without additional charge. Shipments shall be made in order to arrive at the destination at a satisfactory time for unloading during receiving hours.
- 14.2. Per Administrative Rule 606.01(e) "if there is a discrepancy between the unit price and the extension price in a response to an RFP, RFB or RFQ, the unit price shall be binding upon the vendor".
- 14.3. Price decreases shall become effective immediately as they become effective to the general trade or the Vendor's best/preferred customer.

15. AUDITS AND ACCOUNTING:

15.1. The successful Vendor shall allow representatives of the State of New Hampshire to have complete access to all records for the purpose of determining compliance with the terms and conditions of this bid invitation and in determining the award and for monitoring any resulting contract.

16. TERMS OF PAYMENT:

16.1. Payment shall not be due until 30 days after the invoice has been received at the agency business office or all items have been delivered, inspected, and accepted by the agency, whichever is later.

16.2. Payments shall be made via ACH unless otherwise specified by the State of New Hampshire. Use the following link to enroll with the State Treasury for ACH payments: <https://www.nh.gov/treasury/state-vendors/index.htm>.

17. INVOICING:

17.1. Itemized invoices shall be submitted to alexander.j.sitek@wildlife.nh.gov & business@wildlife.nh.gov after delivery of the products and include the following at a minimum:

17.1.1. State of NH purchase order (PO) number

17.1.2. State of NH contract number if applicable

17.1.3. State of NH ordering agency information

17.1.3.1. Name and contact information of ordering individual

17.1.3.2. Name of ordering state agency / department

17.1.3.3. Address of ordering state agency / department

17.1.3.4. Name and contact information of ordering state agency accounts payable office

17.1.4. Date of purchase

17.1.5. Date of delivery

17.1.6. Vendor order number

17.1.7. Vendor account representative name and contact information

17.1.8. Product description, quantity ordered, quantity delivered, unit price, total price for payment

17.2. Payment shall not be due until 30 days after the invoice has been received at the agency business office or all items have been delivered, inspected, and accepted by the agency, whichever is later.

18. AWARD:

18.1. The award shall be made to the Vendor meeting the criteria established in this RFB and providing the **lowest cost in total**. You must bid on all items to be considered. The State reserves the right to reject any or all bids or any part thereof and add/delete items/locations to the contract. The award shall be, in the form of a State of New Hampshire Contract in the form of a purchase order.

18.2. Successful Vendor shall not be allowed to require any other type of purchase order, nor shall the successful Vendor be allowed to require the filling out or signing of any other document by State of NH personnel.

19. BID RESULTS:

19.1. Bid results may be viewed when available, once the award has been made, on our web site only at: <https://apps.das.nh.gov/bidscontracts/bids.aspx>.

19.2. For Vendors wishing to attend the bid closing: Names of the Vendors submitting responses and pricing shall be made public to the above website. In lieu of in person public bid openings the State shall conduct openings via electronic means until further notice.

20. TERMINATION:

20.1. The State of New Hampshire shall have the right to terminate the purchase contract at any time by giving the successful Vendor a thirty (30) day written notice.

21. F.O.B.:

21.1. The F.O.B. shall be destination to the following delivery point (included in the price bid), which means delivered to a state agency's receiving dock or other designated point as specified in this bid or subsequent purchase orders without additional charge:

New Hampshire Fish and Game Headquarters

11 Hazen Drive

Concord, NH 03301

Please contact Alex Sitek 48 hours prior to any delivery

Alex Sitek 603-271-1745

Alexander.J.Sitek@wildlife.nh.gov

FOR QUESTIONS PERTAINING TO THIS BID PLEASE SEE PARAGRAPH 4

21.2. Requisition No.: 256472

22. RETURNED GOODS:

- 22.1. The successful Vendor shall resolve all order and invoice discrepancies within five business days from notification. Products returned due to quality issues, duplicate shipments, over-shipments, etc. shall be picked up by the successful Vendor within ten business days of notification with no restocking or freight charges and shall be replaced with specified products or the agency shall be refunded/credited for the full purchase price. Unauthorized substitutions for any products are not allowed.
- 22.2. The signature of state personnel on shipping documents shall signify the receipt but not the acceptance of the shipment signed for.

23. SPECIFICATION COMPLIANCE:

- 23.1. Vendor's offer shall meet or exceed the required specifications as written. The State of New Hampshire shall be the sole determining factor of what meets or exceeds the required specifications.
- 23.2. Unless otherwise specified by the Bureau of Purchase and Property in this bid invitation document, all equipment/items offered by the Vendor **shall be new** (and of the current model year, if applicable); shall not be used, rebuilt, refurbished; shall not have been used as demonstration equipment, and shall not have been placed anywhere for evaluation purposes.
- 23.3. The manufacturer(s) and/or model(s) indicated in this bid are equivalent to the type and quality required. **You may bid different make(s) and model(s)**; however, your **offer shall match or exceed** the one(s) indicated and you shall demonstrate to the satisfaction of the purchasing Agency that they meet or exceed the minimum standards. Items that do not meet the minimum standards shall not be accepted. Product literature and specifications **MUST** be enclosed.

24. SPECIFICATIONS:

- 24.1. In responding to the bid invitation, the prospective Vendor shall address all requirements for information as outlined herein.
- 24.2. **SPECIFICATIONS:**
 - 24.2.1. Medium Duty Fish Stocking Trucks ****All specs eligible for suitable equivalent substitutes*
 - 24.2.2. 2x – Medium Duty Trucks (33,000 LB Gross Combination Weight) 16' platform bed
 - 24.2.3. 1x – Medium Duty Truck (33,000 LB Gross Combination Weight) 20' platform bed
- 24.3. **Body and Cab**
 - 24.3.1. Type: Full Trucks, Cab and Chassis with 16-20' Platform Body
 - 24.3.2. Cab: Conventional Day Cab 2 seats minimum
 - 24.3.3. Body: Steel frame rail platform w/full headboard wood deck
 - 24.3.4. Body Length: 16-20 feet
 - 24.3.5. Body Width: 8 feet
- 24.4. **Engine and Powertrain**
 - 24.4.1. Engine: Diesel engine (300 HP 800 lb.-ft torque or similar)
 - 24.4.2. Meets current EPA emissions standards
 - 24.4.3. Engine integrated compression brake
 - 24.4.4. Transmission: Heavy duty automatic transmission
 - 24.4.5. Overdrive
 - 24.4.6. On/Off Highway
- 24.5. **Axles**
 - 24.5.1. Axle Front: Minimum 10,000 lb.
 - 24.5.2. Axle Rear: Minimum 21,000 lb.
 - 24.5.3. Axle Rear alt: Tag or tandem axle available on 20' bed truck
- 24.6. **Tires and Suspension**
 - 24.6.1. Tire: Heavy Duty with adequate load rating for max GCW
 - 24.6.2. Suspension: Heavy Duty with adequate load rating for max GCW
 - 24.6.3. Brakes: Heavy Duty with adequate load rating for max GCW
- 24.7. **Lighting**
 - 24.7.1. Lighting: LED where possible
 - 24.7.2. All lighting and reflectors to meet FMVSS-108
 - 24.7.3. Corner strobes
- 24.8. **Additional Equipment**
 - 24.8.1. Additional Equipment:
 - 24.8.2. Mud flaps
 - 24.8.3. Additional Battery/Alternator for electrical equipment (air and water pumps)

29. **NOTE: TO BE CONSIDERED, BID TRANSMITTAL LETTER SHALL BE SIGNED IN THE SPACE PROVIDED.**

30. **THE BID OPENING IS OPEN TO THE PUBLIC ONLINE AT THE FOLLOWING:**

Microsoft Teams meeting

Join: <https://teams.microsoft.com/meet/2849017336832?p=6V3eD6ubQattoNRcO5>

Meeting ID: 284 901 733 683 2

Passcode: rU6Lj2DX

Need help? | System reference

Dial in by phone

+1 603-931-4944,,2257383# United States, Concord

Find a local number

Phone conference ID: 225 738 3#

Join on a video conferencing device

Tenant key: nhgov@m.webex.com

Video ID: 114 354 158 8

More info

For organizers: [Meeting options](#) | [Reset dial-in PIN](#)



STATE OF NEW HAMPSHIRE TRANSMITTAL LETTER

State of New Hampshire
Division of Procurement and Support Services
Bureau of Purchase and Property
25 Capitol Street, Room 102, State House Annex
Concord, NH 03301-6398

Date: 3/31/2026
Bid No.: 125-26
Date of Bid Closing: 4/14/2026
Time of Bid Closing: 11:00 AM (ET)

PLEASE EMAIL ANY QUESTIONS REGARDING THIS BID TO LINCOLN ADAMS AT LINCOLN.J.ADAMS@DAS.NH.GOV.
EMAIL YOUR BID TO: NH.PURCHASING@DAS.NH.GOV.

BID INVITATION FOR MEDIUM DUTY TRUCKS (33,000 LB GROSS COMBINATION WEIGHT)

[Insert name of signor] Justin Barriault, on behalf of New England Rentals [insert name of entity submitting bid (collectively referred to as "Vendor") hereby submits an offer as contained in the written bid submitted herewith ("Bid") to the State of New Hampshire in response to BID 125-26 at the price(s) quoted herein in complete accordance with the bid.

Vendor attests to the fact that:

- 1. The Vendor has reviewed and agreed to be bound by the Bid.
2. The Vendor has not altered any of the language or other provisions contained in the Bid document.
3. The Bid is effective for a period of 180 days from the Bid Closing date as indicated above.
4. The prices Vendor has quoted in the Bid were established without collusion with other vendors.
5. The Vendor has read and fully understands this Bid.
6. Further, in accordance with RSA 21-I:11-c, the undersigned Vendor certifies that neither the Vendor nor any of its subsidiaries, affiliates or principal officers (principal officers refers to individuals with management responsibility for the entity or association):
a. Has, within the past 2 years, been convicted of, or pleaded guilty to, a violation of RSA 356:2, RSA 356:4, or any state or federal law or county or municipal ordinance prohibiting specified bidding practices, or involving antitrust violations, which has not been annulled;
b. Has been prohibited, either permanently or temporarily, from participating in any public works project pursuant to RSA 638:20;
c. Has previously provided false, deceptive, or fraudulent information on a vendor code number application form, or any other document submitted to the state of New Hampshire, which information was not corrected as of the time of the filing a bid, proposal, or quotation;
d. Is currently debarred from performing work on any project of the federal government or the government of any state;
e. Has, within the past 2 years, failed to cure a default on any contract with the federal government or the government of any state;
f. Is presently subject to any order of the department of labor, the department of employment security, or any other state department, agency, board, or commission, finding that the applicant is not in compliance with the requirements of the laws or rules that the department, agency, board, or commission is charged with implementing;
g. Is presently subject to any sanction or penalty finally issued by the department of labor, the department of employment security, or any other state department, agency, board, or commission, which sanction or penalty has not been fully discharged or fulfilled;
h. Is currently serving a sentence or is subject to a continuing or unfulfilled penalty for any crime or violation noted in this section;
i. Has failed or neglected to advise the division of any conviction, plea of guilty, or finding relative to any crime or violation noted in this section, or of any debarment, within 30 days of such conviction, plea, finding, or debarment; or
j. Has been placed on the debarred parties list described in RSA 21-I:11-c within the past year.

This document shall be signed by a person who is authorized to legally obligate the responding vendor. A signature on this document indicates that all State of New Hampshire terms and conditions are accepted by the responding vendor and that any and all other terms and conditions submitted by the responding vendor are null and void, even if such terms and conditions have terminology to the contrary. The responding vendor shall also be subject to State of New Hampshire terms and conditions as stated on the reverse of the purchase order.

Authorized Signor's Signature

[Handwritten Signature]

Authorized Signor's Title

Sales Manager

Bidder Initials: JCB

Date: 4/13/26

GENERAL TERMS AND CONDITIONS

NATURE OF, AND ELIGIBILITY TO RESPOND. This bid invitation is submitted in accordance with Chapter 21-1, and rules promulgated thereunder, and constitutes a firm and binding offer. A bid may not be withdrawn unless permission is obtained from the Bureau of Purchase and Property.

Bids may be issued only by the Bureau of Purchase and Property and are not transferable.

SAMPLES AND DEMONSTRATIONS. When samples are required they must be submitted free of costs and will not be returned. Items left for demonstration or evaluation purposes shall be delivered and installed free of charge and shall be removed at no cost to the State. Demonstration units shall not be offered to the State as new equipment.

BIDS. Bids must be received at the Bureau of Purchase and Property before the date and time specified for the closing. Bids must be submitted on this bid form or exact copies and must be typed or clearly printed in ink. Corrections must be initialed. Bids are to be made less Federal Excise Tax and no charge for handling unless required by law.

SPECIFICATIONS. Vendors must submit on items as specified. Proposed changes must be submitted in writing and received at the Bureau of Purchase and Property at least five (5) business days prior to the bid closing. Vendors shall be notified in writing if any changes to the specifications are made.

AWARD. The award will be made to the responsible Vendor submitting a conforming bid meeting specifications at the lowest cost unless other criteria are noted in the bid. Unless otherwise noted, the award may be made by individual items.

If there is a discrepancy between the unit price and the extension, the unit price will prevail.

When identical low bids are received the award will be made in accordance with the Administrative Rules.

Discounts will not be considered in making award but may be offered on the Invoice for earlier payment and will be applicable on the date of completion of delivery or receipt of Invoice, whichever is later. On orders specifying split deliveries, discounts will apply on the basis of each delivery or receipt of Invoice, whichever is later.

PATENT INFRINGEMENT. Any responding vendor who has reason to believe that any other responding vendor will violate a patent should such responding vendor be awarded the contract shall set forth in writing, prior to the date and time of closing, the grounds for his belief and a detailed description of the patent.

ASSIGNMENT PROVISION. The responding vendor hereby agrees to assign all causes of action that it may acquire under the antitrust laws of New Hampshire and the United States as the result of conspiracies, combinations, or contracts in restraint of trade which materially affect the price of goods or services obtained by the state under this contract if so requested by the State of New Hampshire.

FEDERAL FUNDS. This Division of Plant and Property Management, under RSA 21- I:14, VIII shall assure the continuation or granting of federal funds or other assistance not otherwise provided for by law by following the Federal Procurement Standards.

STATE'S OPTIONS: The Bureau of Purchase and Property reserves the right to reject or accept all or any part of any bid, to determine what constitutes a conforming bid, to award the bid solely as it deems to be in the best interest of the State, and to waive irregularities that it considers not material to the bid.

PUBLIC INFORMATION: The responding vendor hereby acknowledges that all information relating to this bid and any resulting order (Including but not limited to fees, contracts, agreements and prices) are subject to these laws of the State of New Hampshire regarding public information.

PERSONAL LIABILITY: The responding vendor agrees that in the preparation of this bid or the execution of any resulting contract or order, representatives of the State of New Hampshire shall incur no liability of any kind.

PROOF OF COMPLIANCE. The responding vendor may be required to supply proof of compliance with proposal specifications. When requested, the responding vendor must immediately supply the Bureau of Purchase and Property with certified test results or certificates of compliance. Where none are available, the State may require independent laboratory testing. All costs for such testing certified test results or certificate of compliance shall be the responsibility of the responding vendor.

FORM OF CONTRACT. The terms and conditions set forth in any additional Terms and Conditions by the Bureau of Purchase and Property are part of the bid and will apply to any contract awarded the responding vendor unless specific exceptions are taken and accepted and will prevail over any contrary provisions in Terms and Conditions submitted by the responding vendor.

CONTRACT TERMS AND CONDITIONS

1. The State of New Hampshire, acting through the Division of Procurement and Support Services, engages the firm or individual ("the Vendor") to perform the services and/or sale of goods, described in the attached State documents, if any, and the Vendor's bid or quotation, both of which are incorporated herein by reference.
2. **COMPLIANCE BY VENDOR WITH LAWS AND REGULATIONS.** In connection with the performance of this agreement, the Vendor shall comply with all statutes, laws, regulations, and orders of federal, state, county or municipal authorities which shall impose any obligation or duty upon the Vendor, including, but not limited to civil rights and equal opportunity laws.
3. **TERM.** The contract, and all obligations of the parties thereunder, shall become effective on a specified date and shall be completed in their entirety prior to a specified date. Any work undertaken by the Vendor prior to the effective date shall be at his sole risk and, in the event that the contract shall not become effective, the State shall be under no obligation to reimburse the Vendor for any such work.
4. **CONTRACT PRICE.** The contract price, a payment schedule and a maximum limitation of price shall be as specified by the bid invitation and the Vendor's bid. All payments shall be conditioned upon receipt, and approval by the State, of appropriate vouchers and upon satisfactory performance by the Vendor, as determined by the State. The payment by the State of the Contract Price shall constitute complete reimbursement to the Vendor for all expenses of any nature incurred by the Vendor in the performance by the Vendor and complete payment for the Services. The State shall have no other liability to the Vendor.
5. **DELIVERY.** If the vendor fails to furnish items and/or services in accordance with all requirements, including delivery, the state may re-purchase similar items from any other source without competitive bidding, and the original vendor may be liable to the state for any excess costs. If a vendor is unable to complete delivery by the date specified, he must contact the using agency. However, the agency is not required to accept a delay to the original delivery date. All deliveries are subject to inspection and receiving procedure rules as established by the State of New Hampshire. Deliveries are not considered accepted until compliance with these rules has been established. State personnel signatures on shipping documents shall signify only the receipt of shipments. All deliveries shall be FOB Destination.
6. **INVOICING.** All invoices must list Order Number, Unit and Extension Prices and discounts allowed. A separate invoice shall be submitted for each order. Unless otherwise noted on the invitation to bid or purchase order, payment will not be due until thirty (30) days after all services have been completed, or all items have been delivered, inspected and accepted or the invoice has been received at the agency business office, whichever is later.
7. **PERSONNEL.**
 - 7.1. The Vendor shall disclose in writing the names of all owners (5% or more), directors, officers, employees, agents or subcontractors who are also officials or employees of the State of New Hampshire. Any change in this information shall be reported in writing within fifteen (15) days of their occurrence.
 - 7.2. The person signing this agreement on behalf of the State, or his or her delegee ("Contracting Officer") shall be the State's representative for purposes of this agreement. In the event of any dispute concerning the interpretation of this agreement, the Contracting Officer's decision shall be final.
8. **EVENT OF DEFAULT; REMEDIES.**
 - 8.1. Any one or more of the following acts or omissions of the Vendor shall constitute an event of default hereunder ("Events of Default"):
 - 8.1.1. failure to deliver the goods or services satisfactorily or on schedule; or
 - 8.1.2. failure to submit any report required hereunder; or
 - 8.1.3. failure to perform any of the other covenants and conditions of this agreement.
 - 8.2. Upon the occurrence of any Event of Default, the State may take any one, or more, or all, of the following actions:
 - 8.2.1. give the Vendor a written notice specifying the Event of Default and requiring it to be remedied within, in the absence of a greater or lesser specification of time, thirty (30) days from the date of the notice; and if the Event of Default is not timely remedied, terminate this agreement, effective two (2) days after giving the Vendor notice of termination; and
 - 8.2.2. give the Vendor a written notice specifying the Event of Default and suspending all payments to be made under this agreement and ordering that the portion of the Contract Price, which would otherwise accrue to the Vendor during the period from the date of such notice until such time as the State determines that the Vendor has cured the Event of Default, shall never be paid to the Vendor; and
 - 8.2.3. set off against any other obligation the State may owe to the Vendor any damages the State suffers by reason of any Event of Default; and
 - 8.2.4. treat the agreement as breached and pursue any of its remedies at law or in equity, or both.
9. **WAIVER OF BREACH.** No failure by the State to enforce any provisions hereof after any Event of Default shall be deemed a waiver of its rights with regard to that Event, or any subsequent Event. No express failure of any Event of Default shall be deemed a waiver of any provision hereof. No such failure or waiver shall be deemed a waiver of the right of the State to enforce each and all of the provisions hereof upon any further or other default on the part of the Vendor.
10. **VENDOR'S RELATION TO THE STATE.** In the performance of this agreement the Vendor is in all respects an independent contractor, and is neither an agent nor an employee of the State. Neither the Vendor nor any of its officers, employees, agents or members shall have authority to bind the State nor are they entitled to any of the benefits, workmen's compensation or emoluments provided by the State to its employees.
11. **ASSIGNMENT AND SUBCONTRACTS.** The Vendor shall not assign, or otherwise transfer any interest in this agreement without the prior

written consent of the State. No work required by this contract shall be subcontracted without the prior written consent of the State.

12. INDEMNIFICATION. The contractor shall defend, indemnify and hold harmless the State, its officers and employees, from and against any and all losses suffered by the State, its officers and employees, and any and all claims, liabilities or penalties asserted against the State, its officers and employees, by or on behalf of any person, on account of, based on, resulting from, arising out of (or which may be claimed to arise out of) the acts or omissions of the Vendor. Notwithstanding the foregoing, nothing herein contained shall be deemed to constitute a waiver of the sovereign immunity of the State, which immunity is hereby reserved to the State. This covenant shall survive the termination of this agreement.

12.1 PATENT PROTECTION. The seller agrees to indemnify and defend the State of New Hampshire from all claims and losses resulting from alleged and actual patent infringements and further agrees to hold the State of New Hampshire harmless from any liability arising under RSA 382-A:2-312(3). (Uniform Commercial Code).

13. TOXIC SUBSTANCES. In compliance with RSA 277-A Toxic Substances in the Workplace known as the Workers Right to Know Act, the vendor shall provide Safety Data Sheets (277-A:4 Safety Data Sheets) for all products covered by said law.

14. NOTICE. Any notice by a party hereto to the other party shall be deemed to have been duly delivered or given at the time of mailing by certified mail, postage prepaid, in a United States Post Office addressed to the parties at the addresses given below.

15. AMENDMENT. This agreement may be amended, waived or discharged only by an instrument in writing signed by the parties hereto.

16. CONSTRUCTION OF AGREEMENT AND TERMS. This agreement shall be construed in accordance with the laws of the State of New Hampshire, and is binding upon and inures to the benefit of the parties and their respective successors and assigns.

17. ADDITIONAL PROVISIONS. The additional provisions (if any) have been set forth as Exhibit "A" hereto.

18. ENTIRE AGREEMENT. This agreement, which may be executed in a number of counterparts, each of which shall be deemed an original, constitutes the entire agreement and understanding between the parties, and supersedes all prior agreements and understandings relating hereto.



**STATE OF NEW HAMPSHIRE
DIVISION OF PROCUREMENT AND SUPPORT SERVICES
BUREAU OF PURCHASE AND PROPERTY
STATE HOUSE ANNEX
25 CAPITOL STREET
CONCORD, NEW HAMPSHIRE 03301-6398**

Date of Change: April 9, 2026

ADDENDUM # 02 TO BID INVITATION # 125-26

DATE AND TIME OF BID CLOSING: 4/23/2026 11:00 AM

FOR: Medium Duty Trucks (33,000 LB Gross Combination Weight)

Question 6:

In response to question 3 the answer was:

The state is looking for a tag axle, pusher axle, or tandem axle with a 33,000 GCW. The GCW cannot exceed 33,000 pounds. I'm not sure how the state expects this to be met? Can you offer any reference to a vehicle set up you have for our review?

State Response:

The longer 20' bed truck is replacing a single rear axle Kenworth T300 with a pusher lift axle. The lift axle is only used during fully loaded with 2000 gallons water and fish. Pictures of current vehicles and engine models for each truck to be replaced.

Question 7:

Would the state be willing to give an extension on this bid so we have more time to explore the options to meet your GCW needs which is rather challenging at this time? Could we be given an extra 5-7 days?

Bid Currently reads:

7. TIMELINE:

7.1. The timeline below is provided as a general guideline and is subject to change. Unless stated otherwise, consider the dates below a "no later than" date.

Bid Solicitation distributed on or by:	3/31/2026
Last day for questions, clarifications, and/or requested changes to bid:	4/9/2026
States response to questions, clarifications, and/or requested changes to bid:	4/13/2026
Bid Closing (Eastern Time):	4/14/2026 11:00 AM

Bid Changed to Read:

7. TIMELINE:

7.1. The timeline below is provided as a general guideline and is subject to change. Unless stated otherwise, consider the dates below a "no later than" date.

Bid Solicitation distributed on or by:	3/31/2026
Last day for questions, clarifications, and/or requested changes to bid:	4/20/2026
States response to questions, clarifications, and/or requested changes to bid:	4/21/2026
Bid Closing (Eastern Time):	4/23/2026 11:00 AM

Below are the models that will be being replaced.

Model: 2005 Freightliner
Engine: Caterpillar C7 211-
7870

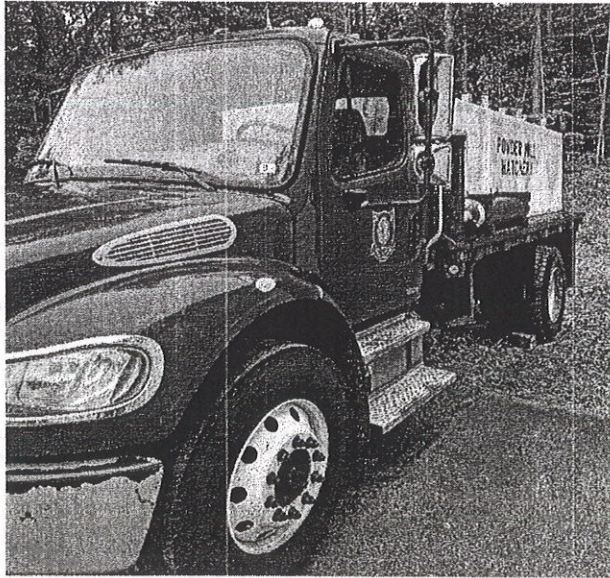

Model: 2004 Chevy C7500
Engine: Isuzu 6HK1X



Model: 2007 Kenworth T300
Engine: Caterpillar C7
W/ accessory pusher axle

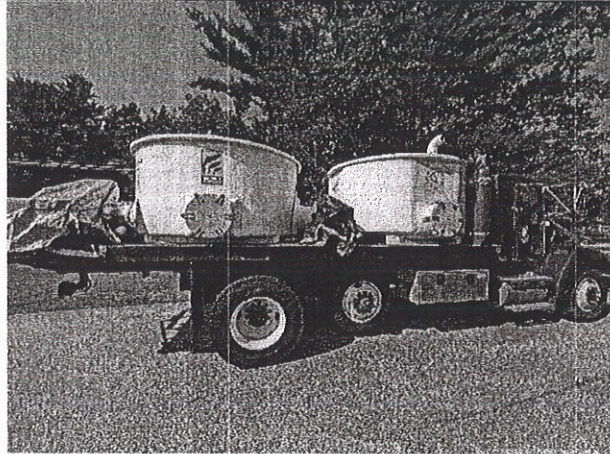

PURCHASING AGENT: Lincoln Adams
Email: NH.Purchasing@das.nh.gov

NOTE: ALL CHANGES TO BID SOLICITATION NOTED IN ADDENDUMS WILL SUPERSEDE PREVIOUSLY SUBMITTED DOCUMENTS AND MUST BE SUBMITTED WITH THE BID. ALL OTHER SPECIFICATIONS REMAIN UNCHANGED AND VALID.

RESPONDENT BUSINESS NAME: New England Kenvath

ADDRESS: 24 Hall St, Concord, NH 03301

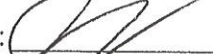
PRINT NAME: Justin Barriault SIGNATURE: 

TEL. NO. 603-581-9085 EMAIL ADDRESS: Justin.Barriault@NewEnglandKW.com

Please visit: <https://das.nh.gov/purchasing/vendorresources.aspx> (click on "Bid and Proposals") for complete bid and addendums.



STATE OF NEW HAMPSHIRE
DIVISION OF PROCUREMENT AND SUPPORT SERVICES
BUREAU OF PURCHASE AND PROPERTY
STATE HOUSE ANNEX
25 CAPITOL STREET
CONCORD, NEW HAMPSHIRE 03301-6398

Date of Change: April 7, 2026

ADDENDUM # 01 TO BID INVITATION # 125-26

DATE AND TIME OF BID CLOSING: 4/14/2026 11:00 AM

FOR: Medium Duty Trucks (33,000 LB Gross Combination Weight)

Question 1:

On this bid for the 20' platform body, they mention a tandem or tag axle chassis for the 20' platform. Is that what they want, or are they looking at it as an option, if available ??

State Response:

The 20' platform body will need a tax axle at minimum. Tandem axle is an acceptable alternative if the vehicle remains within the Class 7 GVWR as specified by our funding source. The 20' bed truck will be used to transport two large water tanks 1,000 gallon volume each. Total load weight is close to 17,000 pounds at maximum capacity.

Question 2:

24.8.3 Additional battery/alternator for electrical equipment: I can provide the extra battery from the factory but not the second alternator. Would a larger more powerful alternator be acceptable instead of the additional one?

State Response:

Yes, an extra battery with a more powerful alternator would be acceptable.

Question 3:

24.5.3 Tag or tandem axle on the 20' bed truck: As stated in 24.2.3 you're looking for a 33,000 GCW, adding an additional axle will supersede that. For clarification are you looking for a minimum 33,000 GCW and anything more would be acceptable?

State Response:

The state is looking for a Tag Axle, pusher axle, or tandem axle, with a 33,000 GCW. The GCW cannot exceed 33,000 lbs.

Question 4:

Upon speaking with my upfitter the tandem axle will be an issue for the Ford Medium Duty, is this something that the State is flexible with?

State Response:

The state is flexible on tag, pusher, or tandem axle so long as it meets the written specs.

Question 5:

If we were to place an order for these vehicles, as we do not have any on the ground, we are looking at the chassis being produced in July or August. Is there flexibility as far as the timeline goes?

State Response:

The state will accept delivery no later than 10/31/26.

Specifications added:

Added: Spec 24.8.4 – For only the 20' Flatbed a PTO truck bed lift system is required.

Clarification:

All truck will need the capability to haul 2,000 gallons of water, for NH F&G fish stocking purposes.

PURCHASING AGENT: Lincoln Adams
Email: NH.Purchasing@das.nh.gov

NOTE: ALL CHANGES TO BID SOLICITATION NOTED IN ADDENDUMS WILL SUPERSEDE PREVIOUSLY SUBMITTED DOCUMENTS AND MUST BE SUBMITTED WITH THE BID. ALL OTHER SPECIFICATIONS REMAIN UNCHANGED AND VALID.

RESPONDENT BUSINESS NAME: Neu England Network

ADDRESS: 24 Hall St, Concord, NH 03301

PRINT NAME: Justin Barriault SIGNATURE: 

TEL. NO. 603-581-9085 EMAIL ADDRESS: Justin.Barriault@NeuEnglandNW.com

Please visit: <https://das.nh.gov/purchasing/vendorresources.aspx> (click on "Bid and Proposals") for complete bid and addendums.



NEW ENGLAND KENWORTH - CONCORD (Y150)
 24 HALL STREET
 CONCORD, New Hampshire 03301

STATE OF NEW HAMPSHIRE
 29 HAZEN DR
 CONCORD, New Hampshire 03302
 United States of America

Justin Barriault
 Cell Phone: 603-581-9085
 Office Phone: 603-226-2000
 Email: justin.barriault@newenglandkw.com

LINCOLN ADAMS
 Email: lincoln.j.adams@das.nh.gov

Vehicle Summary

Model:	Unit	Chassis	
Type:	T380 Series Conventional Full Truck	Fr Axle Load (lbs):	12000
Description 1:	16ft tx8 no comp brake	Rr Axle Load (lbs):	21000
Description 2:		G.V.W.R. (lbs):	33000
		G.C.W. (lbs):	33000
Intended Serv.:	Application	Road Conditions:	
Commodity:	Local Pickup & Delivery: Vehicles which General Freight	Class A (Highway)	90
Type:	Body	Class B (Hwy/Mtn)	10
Length (ft):	Van	Class C (Off-Hwy)	0
Height (ft):	18	Class D (Off-Road)	0
Max Laden Weight (lbs):	4000	Maximum Grade:	6
		Wheelbase (in):	190
No. of Trailer Axles:	Trailer	Overhang (in):	80
Type:	0	Fr Axle to BOC (in):	69.5
Length (ft):	0	Cab to Axle (in):	120.5
Height (ft):	0	Cab to EOF (in):	200.5
Kingpin Inset (in):	0	Overall Comb. Length (in):	310
Corner Radius (in):	0		
Length (ft):	Restrictions	Special Req.	
Width (in):	75	U.S. Domestic Registry, 50-state.	
Height (ft):	102		
	13.5		

Approved by: _____

Date: _____

Note: All sales are F.O.B. designated plant of manufacture.

Price Level: January 1, 2026
 Deal: 16ft tx8 no comp brake
 Printed On: 4/22/2026 4:03:15 PM

100% Complete

Date: April 22, 2026
 Quote Number: QUO-1177578-M6F4V4



Sales Code	Std/Opt	Description	Weight
Model			
0000380	S	T380 Series Conventional	9,930
0070086	S	T380 Aero Hood	0
0072000	O	Chassis Operation Will Not Incl. Stationary application. Stationary operation is defined as running the engine under load while stationary at a substantial fraction of engine gross horsepower (60% or greater) for an extended period of time (longer than 5 - 10 minutes).	0
0080101	O	CARB Low NOX Omnibus Registration Guidelines Dealer/Customer acknowledges that this vehicle is NOT intended for registration or domicile/primary use in the State of California.	0
0080314	O	EPA Clean Idle Label - PACCAR PX Engines	0
0090143	O	T380 Automatic	0
0098429	O	State of Registry: New Hampshire	0
Engine & Equipment			
0130219	O	PACCAR PX-9 300 300@1850 860@1200, 2024 With Turbo Exhaust Brake (VGT Brake) N09420 C333 0.....Reserve Speed Limit Offset (N09380 C334 0.....Maximum Cycle Distance (C334 N09360 C400 252...Reserve Speed Function Reset N09200 C399 100...Standard Maximum Speed Limit N09400 C401 10...Maximum Active Distance (C40 N09220 C402 0.....Expiration Distance (C402) N09540 C395 0.....Expiration Distance (C395) N09260 C121 70...Max Vehicle Speed in Top Gea N09440 C234 NO....Engine Protection Shtdwn N09460 C231 NO....Gear Down Protection N09580 C133 5.....Idle Shtdwn Time N09680 C233 NO....dle Shtdwn Override N09480 C132 1400..Max PTO Speed N09300 C128 70...Max Cruise Control Speed N09500 C239 NO....Cruise Control Auto Resume N09520 C238 NO....Auto Engine Brake in Cruise N09780 C190 80...High Ambient Temperature Thr N09740 C188 40...Low Ambient Temperature Thre N09760 C189 60...Intermediate Ambient Tempera N09720 C382 YES..Enable Hot Ambient Automatic N09600 C396 YES..Enable Impending Shutdown Wa N09620 C397 60...Timer For Impending Shutdown N09640 C206 35...Engine Load Threshold N09560 C225 NO....Enable Idle Shutdown Park Br	694
1000046	O	EPA Emissions Compliant Engine	0

Price Level: January 1, 2026
Deal: 16ft tx8 no comp brake
Printed On: 4/22/2026 4:03:15 PM

100% Complete

Date: April 22, 2026
Quote Number: QUO-1177578-M6G4V4



Sales Code	Std/Opt	Description	Weight
1000151	S	PremierSpec	0
1000243	O	Gearing Analysis: Performance power before economy results.	0
1000257	O	Customer's Typical Operating Spd: 70 MPH	0
1000344	O	EWI Tracking - A2 Engine Module Chassis	0
1000526		RegistrationYear Year of Registration: 2026	0
1000684		Effective VSL Setting NA	0
1000858	O	Engine Idle Shutdown Timer Disabled	0
1000891		Eff EIST NA Expiration Miles Use only with MX and Cummins engines	0
1002060	S	Air Compressor: Cummins 18.7 CFM - Cummins and PX	0
1041399	S	Air Cleaner: MD Composite Engine Mounted	0
1098003	S	Air Restriction Indicator: Mechanical Mounted on Air Cleaner.	0
1105231	O	Fan Hub: Horton On/Off for PX-9 or L9N	0
1121231	S	Cooling Module: 2.1M MD - Aero Hood 1000 Square Inches	0
1247247	O	EXH: Single Can 2024 RH Under with RH Horizontal Tailpipe Below Rail	0
1321102	S	Fuel Filter: PACCAR 2.1M MD for PX-7 or PX-9 Fuel/water separator for 2021 and later engines.	0
1321200	S	Run Aid:None *For Fuel Filter	0
1321300	S	Start Aid:None *For Fuel Filter	0
1504006	O	Block Heater: PACCAR 750 watt 120V for PX-7 and B6.7N. 1000 watt for PX-9 and ISL9 Engines.	2
1816200	O	Alternator: SEG 200 amp, Brush Type Formerly Bosch.	0
1821220	S	Batteries: 2 PACCAR GP31 Threaded Post (700-730) 1400-1460 CCA dual purpose.	0
1836106	O	Mitsubishi 105P55 12V Starter with Cummins and PX PACCAR 12 volt electrical system. W/ centralized power distribution incorporating plug-in style relays. Circuit protection for serviceability, 12- volt light system w/circuit protection circuits number & color coded. Only for Cummins or PX engines.	0
1840065	S	12V Low Voltage Disconnect for Battery Protection	0
1901018	S	Remote PTO/Throttle, 12-Pin, 250K, Back of Cab OR Back of Sleeper, J1939, Remote Control Provision	0

Price Level: January 1, 2026
Deal: 16ft tx8 no comp brake
Printed On: 4/22/2026 4:03:15 PM

100% Complete

Date: April 22, 2026
Quote Number: QUO-1177578-M6F4V4



Sales Code	Std/Opt	Description	Weight
Transmission & Clutch			
2020107	O	Transmission: PACCAR TX-8, Without HSA, 860 LB FT Automatic, 8 Speed, With PTO Provision, 8AP860	0
2406440	O	Driveline: 2 Dana SPL140 1 Centerbearing	68
2409941	O	One Heavy-Duty One-Piece Aluminum Crossmember This option upgrades an existing crossmember. The cost does not include the centerbearing and bracket. Crossmember location will be in accordance with Kenworth engineering standards, using the major components specified on the DTPO.	0
2410806	O	Torque Converter: TP1150N for PACCAR TX-8	0
2429094	O	C/I First PACCAR TX-8 PTO 3 O'Clock Position	0
2429358	O	Rear Transmission Support Springs for transmission PTO applications are required to ensure that engine flywheel housings are not overloaded when transmission PTO's are installed.	0
Front Axle & Equipment			
2532108	S	Hendrickson SteerTek Front Axle rated 12K Standard Track 3.32 in. drop.	0
2621310	S	Front Brakes: 14.6K Bendix ES S-Cam 16.5x5 in.	0
2659047	O	Front Dustshield: for Drum Brakes: All Front Axles.	6
2690002	S	Front Brake Drums: 14.6K 16.5x5 in. cast.	0
2702500	S	Front Hub: Iron Hub Pilot 14,600 lbs. 11-1/4 in. bolt circle. For use w/ air disc brakes. Consider wheelguards (5850002) w/ aluminum wheels.	0
2741970	S	ConMet PreSet Plus Hub Package; Front Axle.	0
2750001	S	Hubcap: Front Vented.	0
2765001	S	Front Auto Slack Adjuster for Drum Brakes.	0
2863019	O	Front Springs: Taperleaf 12K w/ shock absorbers. With maintenance-free elastomer spring pin bushings.	58
2895223	S	Single Power Steering Gear: 13.2K for Air Brakes.	0
2900058	O	30 mm Front Suspension Spacer Block	0
Rear Axle & Equipment			
3032200	S	Single Meritor MS21-14x4 Rear Axle rated at 21K.	0
3200557	S	Rear Axle Ratio - 5.57.	0

Price Level: January 1, 2026
 Deal: 16ft tx8 no comp brake
 Printed On: 4/22/2026 4:03:15 PM

100% Complete

Date: April 22, 2026
 Quote Number: QUO-1177578-M6F4V4



Sales Code	Std/Opt	Description	Weight
3330004	S	Single Rear Brakes 16-1/2x7 in. Bendix ES- extended service S-cam.	0
3392007	S	Single Rear Brake Drums: Cast S-Cam Single For use with 15x8.625", 16.5X7" or 16.5X8.625" brake.	0
3403220	S	Single Rear Hubs: Iron Hub Pilot 26k; 11.25" Bolt circle. Requires "R" series outer ends.	0
3441971	S	ConMet PreSet Plus Hub Package; Single Rear Axle.	0
3465001	S	Single Rear Axle Automatic Slack Adjusters. For use with drum brakes.	0
3485007	S	Spring Brake: 3030 Long Stroke Single 3 in. travel. For drum brakes. Helps keep brakes in adjustment longer.	0
3490047	O	Dustshields for Drum Brakes: All Rear Axles.	11
3495226	S	Bendix 4S/4M Anti-Lock Brake System.	0
3495561	O	Air Operated Park Brake	0
3636421	S	Rear suspension: single Reyco 79KB taperleaf 21K. Medium-duty. Unladen Height: 9 in. Laden Height: 7.5 in. Not rear air disc brake compatible.	0
3836315	O	Bolted Rear Suspension Crossmembers for Reyco 79KB. Replaces medium duty standard.	41
Tires & Wheels			
4079065	O	Front Tires: Bridgestone R273 Ecopia 11R22.5 14PR 14PR	0
4217094	O	Rear Tires: Michelin XDN2 11R22.5 16PR 41.7 in. diameter, drive. 19.5 in. SLR. Code is priced per pair of tires.	60
4899106	S	Tire pressure monitoring system for tire/wheel count: 6.	0
4900004	O	Rear Tire Quantity: 4	0
5042292	S	Front Wheel: Accuride 51455 22.5x8.25 steel Steel Armor[TM] powder coat, hub-pilot mount. 7400lb. maximum rating. 5-hand hole. Air disc brake compatible.	0
5242392	S	Rear Wheel: Accuride 51455 22.5x8.25 steel Steel Armor[TM] powder coat, hub-pilot mount. 7400lb. maximum rating. 5-hand hole. Air disc brake compatible. Code is priced per pair of wheels.	0
5853906	O	Powder Coat White Steel Wheel. Use in Conjunction with front, dual front, rear, spare or lift axle wheel code(s). All wheels on chassis must have same finish color.	0
5900004	O	Rear Wheel/Rim Quantity: 4	0
Frame & Equipment			
6056400	O	Frame Rails: 10-3/4 x 3-1/2 x 3/8in. Steel 285in.	346

Price Level: January 1, 2026

100% Complete

Date: April 22, 2026

Deal: 16ft tx8 no comp brake

Quote Number: QUO-1177578-M6F4V4

Printed On: 4/22/2026 4:03:15 PM



Sales Code	Std/Opt	Description	Weight
		to 336 in. Truck frame weight is 3.48 lb.-in. per pair of rails. Section modulus is 17.80, RBM is 2,132,000 in-lbs per rail. Frame rail availability may be restricted based upon application, axle/suspension capacity, fifth wheel setting, or component/dimensional specifications. The results of the engineering review may result in a change to the requested frame rail. If a change is required Kenworth Application Engineering will advise the dealer of the appropriate material specification for a substitute rail.	
6302460	O	Bumper: Tapered Painted Steel Channel. Requires a bumper setting code.	65
6319040	S	40 in. Bumper Setting. Requires a Bumper Code.	0
6321010	S	Front Tow Loops: Two	0
6404420	O	Battery Box: Steel Parallel Module under W/Step, natural aluminum cover. Use with 2 or 3 batteries. Up to 2 air tanks may be mounted to bottom of box. Batteries will be oriented perpendicular to the frame rail in a single row.	9
6409901	O	Battery Box Location: LH Side.	0
6451125	O	DPF/SCR Box Natural End Plates and Natural cover.	0
6490139	O	Heavy-Duty One-PC Aluminum Intermediate/ Fill-In crossmember.	13
6490433	O	Heavy-Duty 5-Piece Rear Cab Support, Hucked assembly. Huck fastened to frame.	15
6742009	S	Square End-of-Frame W/O Crossmember; Non-Towing.	0
Fuel Tanks & Equip			
7144050	O	50 US Gallon D-Shape Rectangular Aluminum BOC fuel tank, replace.	-22
7722173	O	Large DEF Tank, 15 Gallons.	26
7889007	O	Fuel Fill: Center of Tank(s) BOC. Not available on fuel tanks with 3 supports or with full or partial chassis fairings.	0
7889203	O	DEF to Fuel Fill Ratio 2:1 or Greater.	0
7889614	O	DEF Tank Location is LH BOC. For 2.1M Medium-Duty	0
7940050	O	Location: 50 gal fuel tank LH behind cab.	0
Cab & Equipment			
8024311	S	Cab: Stamped Aluminum with Curved Windshield LED markers. Requires separate roof code.	0
8090152	O	Hood: Med Aero w/ Dark Gray Crown In-Mold Color	0
8108011	S	Cab HVAC - Day Cab and 40 in. Sleeper	0

Price Level: January 1, 2026

Deal: 16ft tx8 no comp brake

Printed On: 4/22/2026 4:03:15 PM

100% Complete

Date: April 22, 2026

Quote Number: QUO-1177578-M6F4V4



Sales Code	Std/Opt	Description	Weight
		System With Defrost, A/C, and 48,000 BTU/hr Heater. Includes automatic temperature control with one touch defrost operation and dash mounted cab temperature and solar intensity sensors. Pleated fresh air filter and cabin recirculation air filter standard. The Kenworth HVAC system is designed to provide optimal heating and cooling in all operating environments without need for additional insulation. Cab HVAC without sleeper heater AC is available with 40in sleeper.	
8201013	S	Steering Wheel: 18 in. 4-Spoke.	0
8201052	O	Column Mtd TMSN Control W/Retarder Cntrl, RH Side Use with Automated and Automated Manual Transmissions Only	0
8201200	S	Adjustable Telescoping Tilt Steering Column.	0
8205164	O	Dash Switch: 1st Single-Acting Eaton or PACCAR MTD PTO Electric switch, wiring, software, air solenoids, and plumbing are factory-installed to control the 1st Eaton (single-acting) transmission PTO.	0
8208475	O	Two Spare Switches: Wired to Power. BOC Wire termination.	0
8282024	S	Main Instrument Package: 7" Digital Display Cluster. Includes Physical (Analog): Speedometer, Tachometer, Oil Pressure, and Coolant Temp; and Digital: Fuel Level #1, DEF Level, DPF Filter Status, Fuel Economy, Volts Telltale, OAT and Primary Air Pressure, Secondary Air Pressure, and Air Application for air brake trucks.	0
8330591	S	Interior Trim Package: 2.1M MD Gray Foam Backing/Cloth Headliner W/Gray Sunvisor & Seat Color Three Underdash Center Console Cupholders (Two If Allison Transmission Is Selected).	0
8410122	O	Driver Seat: KW Air Seat HB Vinyl w/ Dual Armrests/Susp Cover	0
8480232	O	Rider Seat: KW Toolbox Seat HB Vinyl w/ Dual Armrests/Record Holder/Occupancy Sensor	0
8698970	S	No Radio Or Speakers Selected: No Prewire & No Antenna Wiring. Not w/ Smart Wheel.	0
8700196	S	Turn Signal: Self-Cancelling	0
8700283	S	LH and RH Trip Ledge Rain Deflectors	0
8700601	S	Global Telematics Unit	0
8702232	S	Sensata Tire pressure monitoring system Requires 48991XX tire/wheel count code for sensors.	0
8800372	O	Grabhandle: LH, Exterior, Side of Cab - Ergonomic Grab Handle Mounted To The Left Hand Exterior Of The Cab For Entry and Exit.	3
8800402	S	Dual Cab Interior Grabhandles: A Pillar Mounted Dash Wrap and B Pillar Mounted Grabhandles	0
8832113	S	Kenworth Daylite Door With Standard LH/RH electric door locks and LH/RH electric window controls.	0

Price Level: January 1, 2026

100% Complete

Date: April 22, 2026

Deal: 16ft tx8 no comp brake

Quote Number: QUO-1177578-M6F4V4

Printed On: 4/22/2026 4:03:15 PM



Sales Code	Std/Opt	Description	Weight
8841411	O	Single Air Horn Under Cab.	0
8850139	S	Look-Down, Pass. Door, Black 11x6	0
8850842	S	Mirror Shell: Dual Aero In-Mold Black	0
8860852	O	Mirror: Dual KW Aero Rear View Motor, heated with Integral CX.	0
8871446	S	Rear Cab Stationary Window 19in x 36in	0
8890101	S	One-Piece Bonded-In Windshield With Curved Glass. Standard.	0
8890881	S	Direct Mount, Rubber Isolated Cab Suspension.	0
8891011	O	Roof: Raised Profile, Stamped Aluminum w/ Additional Head Room & Interior Overhead Storage	0
Lights & Instruments			
9010803	S	Headlamps: Single Halogen Complex Reflector w/ Turn Indicator, Reflector and DRL. Fender Mtd.	0
9020101	S	14-Pin RP170 Body Lighting Connector.	0
9022130	O	Marker Lights: Five Rectangular LED. Chrome housing. For use with raised roof only. Required with exterior sunvisor.	0
9030052	S	LED Stop,Turn,Tail: With Two LED Backup Lights and With An LED License Plate.	0
9090049	O	Omit Brake Light with Engine Brake. Can only be selected when chassis also has engine brake. Cannot be used with options to delete engine brake.	0
9090180	O	Backup Alarm: Tail Light Bracket Mounted Variable self-adjusting 82-102 DBA.	0
Air Equipment			
9101218	S	Air Dryer: Bendix AD-HF Puraguard Heated	0
9108001	S	Moisture Ejection Valve W/ Pull Cable Drain.	0
9140020	S	Nylon Air Tubing in Frame & Cab, Excluding Hoses subject to excessive heat or flexing.	0
Extended Warranty			
9200008	O	Base Warranty - PACCAR PX-9 Engine 24 months / 250,000 miles / 402,336 km / 6250 hours.	0
9200022	S	Base Warranty - Standard Service Medium Duty 12 months / Unlimited miles & km	0
9212661	O	TruckTech+ RD - 5YR Sub PACCAR PX Engines	0
9220001	O	Base Warranty: Emissions 5YR/100K MI	0

Price Level: January 1, 2026
 Deal: 16ft tx8 no comp brake
 Printed On: 4/22/2026 4:03:15 PM

100% Complete

Date: April 22, 2026
 Quote Number: QUO-1177578-M6F4V4



Sales Code	Std/ Opt	Description	Weight
Miscellaneous			
9409852	O	GHG Secondary Manufacturer: Does Not Apply	0
9490206	O	Warning Triangle Reflector Kit: Shipped Loose. Kit consists of 3 triangles in plastic carrying case. Not floor mounted.	4
9490404	O	One 5 lb. Dry Chemical Type Fire Extinguisher mounted outboard of driver seat. Class ABC.	11
9491652	S	EMUX Architecture	0
Promotions			
9511431	O	Model Year 2026 Engine	0
Paint			
9700000	O	Paint Color Number(s). N9702 A - Z9990 UNPUBLISHED PAINT N9770 BUMPER N0001 BLACK N9720 FRAME N0001 BLACK	0
9943014	O	Steel Bumper Painted Frame Color	0
9943052	O	Day Cab Pearl Metallic Paint	0
9944820	S	1 - Color Paint - Day Cab Color will be White if no other color is specified.	0
9960003	O	Non-Standard Paint Color. <i>Narr TBD</i>	0
9965510	S	Base Coat/ Clear Coat. The Kenworth Color Selector contains additional instructions, as well as information on Kenworth paint guidelines and surface finish applications. Kenworth is standard with Dupont Imron Elite paint.	0

Special Requirements

- Special Requirement 1 0098025
- Special Requirement 2
- Special Requirement 3
- Special Requirement 4

Fuel Efficiency Score:

Order Comments

Price Level: January 1, 2026
 Deal: 16ft tx8 no comp brake
 Printed On: 4/22/2026 4:03:15 PM

100% Complete

Date: April 22, 2026
 Quote Number: QUO-1177578-M6F4V4



Total Weight (lbs)

11,340

Any price increase as the result of force majeure, rising costs of components (including but not limited to material shortages) or government tariffs are not included in the quoted price and will be the financial responsibility of the customer.

Prices and Specifications Subject to Change Without Notice.

Unpublished options may require review/approval.
Dimensional and performance data for unpublished options may vary from that displayed in CRM.

PRICING DISCLAIMER

While we make every effort to maintain the web site to preserve pricing accuracy, prices are subject to change without notice. Although the information in this price list is presented in good faith and believed to be correct at the time of printing, we make no representations or warranties as to the completeness or accuracy of this information. We reserve the right to change, delete or otherwise modify the pricing information which is represented herein without any prior notice. We carefully check pricing specifications, but occasionally errors can occur, therefore we reserve the right to change such prices without notice. We disclaim all liability for any errors or omissions in the materials. In no event will we be responsible for any damages of any nature whatsoever from the reliance upon information from these materials. Please check your order prebills to confirm your pricing information

Price Level: January 1, 2026
Deal: 16ft tx8 no comp brake
Printed On: 4/22/2026 4:03:15 PM

100% Complete

Date: April 22, 2026
Quote Number: QUO-1177578-M6F4V4



Shipping Destinations

Intermediate Destination:

Final Destinations	Quantity
--------------------	----------

Price Level: January 1, 2026
Deal: 16ft tx8 no comp brake
Printed On: 4/22/2026 4:03:15 PM

100% Complete

Date: April 22, 2026
Quote Number: QUO-1177578-M6F4V4

FRAME RAKE

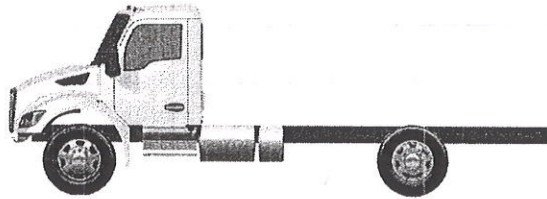

The listed heights should be considered approximations due to variations which may occur in component manufacturing processes, spring set, and the way in which the vehicle is loaded.

Component	Sales Code	Description	Laden	Unladen
Frame	6056400	Frame Rails: 10-3/4 x 3-1/2 x 3/8in. Steel 285in.	10.8	10.8
Front Spring	2863019	Front Springs: Taperleaf 12K w/ shock absorbers.	6.4	9.6
Front Axle Drop 3.5"	2532108	Hendrickson Steerlok Front Axle rated 12K	0.2	0.2
Height Adj.	2900058	30 mm Front Suspension Spacer Block	1.2	1.2
Front Tires	4079065	Front Tires: Bridgestone R273 Ecopia 11R22.5 14PR	19.3	19.8
Front Frame Height			37.8	40.5
Frame	6056400	Frame Rails: 10-3/4 x 3-1/2 x 3/8in. Steel 285in.	10.8	10.8
Subframe	0000000	No sub frame	0	0
Suspension	3636421	Rear suspension: single Reyco 79K8 taperleaf 21K.	7.5	9.0
Rear Tires	4217094	Rear Tires: Michelin XDN2 11R22.5 15PR	19.5	20.6
Rear Frame Height			37.8	40.3
Frame Rake			0.0	-0.2
Frame Rake Slope (%)			0.0	-0.1

*These characteristics are considered to be out of standard range.
Laden rake more than 1% of wheelbase from level (positive or negative).*

HORIZONTAL DIMENSIONS

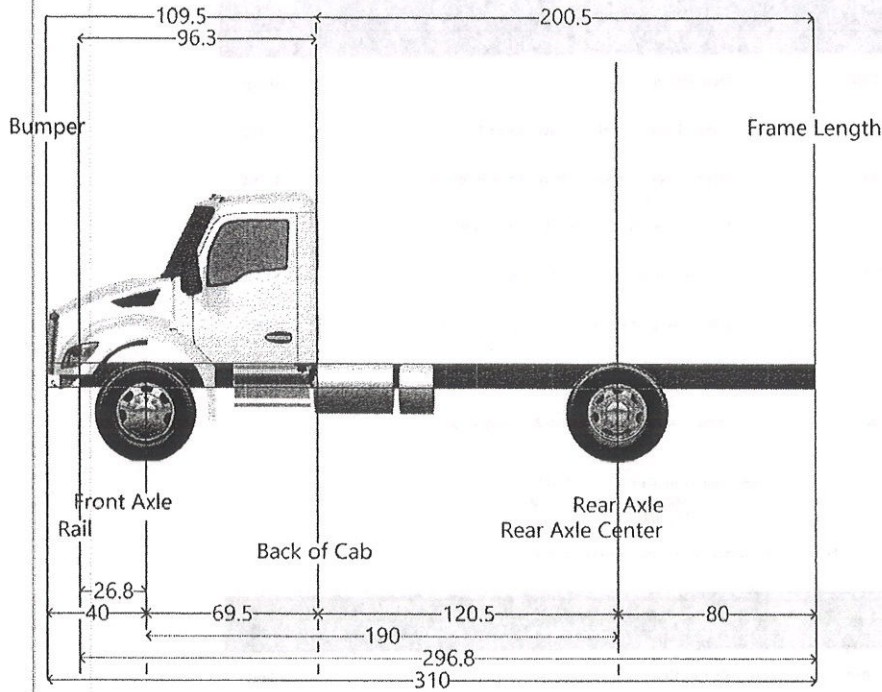

Dimension	Measurement	Start	End
Axle Spacing	0	190	190
Bumper to Back of Cab	109.5	-40	69.5
Bumper to Front Axle	40.0	-40	0
Bumper to Front Frame	13.2	-40	-26.8
Cab to End of Frame	200.5	69.5	270
Cab to Rear Axle	120.5	69.5	190
Effective Bumper to Back Of Cab	109.5	-40	69.5
Frame Length	296.8	-26.8	270
Front Axle to Back of Cab	69.5	0	69.5
Front of Frame to Axle	26.8	-26.8	0
Load Space	200.5	69.5	270
Overall Length	310.0	-40	270
Overhang	80.0	190	270
Pusher Offset #1	0.0	190	190
Pusher Offset #2	0.0	190	190
Pusher Offset #3	0.0	190	190
Tag Offset	0.0	190	190
Wheelbase	190	0	190

VEHICLE WEIGHT RATING

FRONT AXLE COMPONENTS

Component	Sales Code	Description	Ratings
Axle	2532108	Hendrickson Steertek Front Axle rated 12K	12,000
Springs	2863019	Front Springs: Taperleaf 12K w/ shock absorbers	12,000
Power Steering	2895223	Single Power Steering Gear. 13.2K for Air Brakes.	13,200
Hubs, Drums	2702500	Front Hub: Iron Hub Pilot 14,600 lbs.	14,600
Brakes	2621310	Front Brakes: 14.6K Bendix ES S-Cam 16.5x5 in.	14,600
Tires	4079065	Front Tires: Bridgestone R273 Ecopia 11R22.5 14PR	12,350
Wheels	5042292	Front Wheel: Accuride S1455 22.5x8.25 steel	

Requested Front (lbs): 12,000
 Minimum: 0
 Maximum: 12,000

The front axle weight rating cannot exceed 12000

REAR AXLE COMPONENTS

Component	Sales Code	Description	Ratings
Axle	3032200	Single Meritor M521-14x4 Rear Axle rated at 21K.	21,000
Hubs, Drums	3403220	Single Rear Hubs, Iron Hub Pilot 26k; 11.25" Bolt	26,000
Service Brakes	3330004	Single Rear Brakes 16-172x7 in. Bendix ES-	26,000
Spring Brakes	3485007	Spring Brake: 3030 Long Stroke Single 3 in.	26,000
Suspension	3636421	Rear suspension: single Reyco 79KB taperleaf 21K.	21,000
Tires	4217094	Rear Tires: Michelin XDN2 11R22.5 16PR	24,020
Wheels	5242392	Rear Wheel: Accuride S1455 22.5x8.25 steel	29,604

Requested Rear (lbs): 21,000
 Minimum: 10,000
 Maximum: 21,000

The rear axle weight rating cannot exceed 21000

GROSS COMBINATION WEIGHT RATING

GCWR (lbs)	30,000
Min	26,001
Max	200,000

The Gross Combination Weight Rating cannot exceed 200000

FRAME LAYOUT

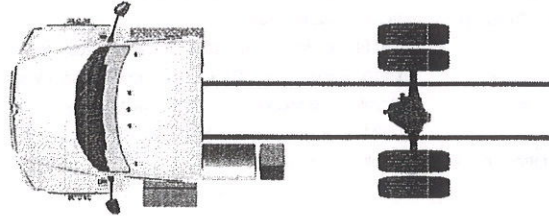

Note: Optional content may be displayed. The order has not yet received an engineering review. The actual arrangement of components may not be exactly as pictured. Additional changes may be made to the layout by Kenworth. Add a Custom Frame Layout code if an exact layout is required.

Selected Options (Wheelbase: 190)

Sales Code	Description	Length	Side
7144050	50 US Gallon D-Shape Rectangular Aluminum BOC	32.7	Left
7722173	Large DEF Tank, 15 Gallons.	14.7	Left
6404420	Battery Box: Steel Parallel Module under W/Step,	31	Left
9101218	Air Dryer: Bendix AD-HF Puraguard Heated	??	??

SPEED & GRADE PERFORMANCE REPORTS

Cruise Report (Engine Fan Off)

Configuration: T330 Series Conventional / Full Truck GCW: 33000
 Quote/DTPO/CO: QUO-1177578-M6F4V4
 Engine: 0130219 PACCAR PX-9 300 300@1850 860@1200, 2024
 Transmission: 2020107 Transmission: PACCAR TX-8, Without HSA, 860 LB FT
 Rear Axle: 3032200 Single Meritor MS21-14x4 Rear Axle rated at 21K.
 Rear Tire: 4217094 Rear Tires: Michelin XDN2 11R22.5 16PR | : 496
 Operating Conditions: 0% Rolling Resistance

Startability	
Transmission Ratio	Maximum Starting Grade
4.89	46.10
3.12	29.41

	700	800	900	1000	1100	1200	1300	1400	1500	1600	1700	1800	1900	2000	2100	2200
Engine RPM:	700	800	900	1000	1100	1200	1300	1400	1500	1600	1700	1800	1900	2000	2100	2200
Gross Torque:	555	630	710	790	825	860	859	859	859	859	859	859	829	788	750	716
Net Torque:	478	552	630	708	743	777	778	780	781	782	783	784	757	719	685	654
Net HP:	64	84	108	135	156	178	193	208	223	238	253	269	274	274	274	274

RAX-Ratio: 5.57

Gear Ratios: TRN (1): 4.89																	
Speed (MPH):		3.1	3.6	4.0	4.4	4.9	5.3	5.8	6.2	6.7	7.1	7.6	8.0	8.4	8.9	9.3	9.8
Grade (%):		23.2	27.2	31.5	35.9	38.0	40.0	40.1	40.2	40.3	40.3	40.4	40.4	40.4	40.6	40.6	40.6
Gear Ratios: TRN (2): 3.12																	
Speed (MPH):		4.9	5.6	6.3	7.0	7.7	8.4	9.0	9.7	10.4	11.1	11.8	12.5	13.2	13.9	14.6	15.3
Grade (%):		14.3	16.7	19.2	21.8	23.0	24.1	24.2	24.2	24.3	24.3	24.3	24.4	23.4	22.2	21.0	20.9
Gear Ratios: TRN (3): 2.03																	
Speed (MPH):		7.5	8.6	9.6	10.7	11.8	12.8	13.9	15.0	16.0	17.1	18.2	19.3	20.3	21.4	22.5	23.5
Grade (%):		9.0	10.5	12.1	13.7	14.5	15.2	15.2	15.2	15.3	15.3	15.3	15.3	14.8	14.0	13.3	12.6
Gear Ratios: TRN (4): 1.64																	
Speed (MPH):		9.3	10.6	11.9	13.2	14.6	15.9	17.2	18.5	19.9	21.2	22.5	23.8	25.2	26.5	27.8	29.1
Grade (%):		7.1	8.4	9.6	10.9	11.5	12.1	12.1	12.1	12.1	12.2	12.2	12.2	11.7	11.1	10.5	10.0
Gear Ratios: TRN (5): 1.25																	
Speed (MPH):		12.2	13.9	15.6	17.4	19.1	20.9	22.6	24.3	26.1	27.8	29.5	31.3	33.0	34.7	36.5	38.2
Grade (%):		5.3	6.2	7.2	8.1	8.6	9.0	9.0	9.0	9.1	9.1	9.1	9.1	8.6	8.3	7.9	7.5
Gear Ratios: TRN (6): 1																	
Speed (MPH):		15.2	17.4	19.5	21.7	23.9	26.1	28.2	30.4	32.6	34.7	36.9	39.1	41.3	43.4	45.6	47.8
Grade (%):		4.1	4.8	5.6	6.4	6.7	7.1	7.1	7.1	7.1	7.1	7.1	7.1	6.9	6.5	6.1	5.8
Gear Ratios: TRN (7): 0.84																	
Speed (MPH):		18.1	20.7	23.3	25.9	28.4	31.0	33.6	36.2	38.8	41.4	44.0	46.5	49.1	51.7	54.3	56.9
Grade (%):		3.3	3.9	4.6	5.2	5.5	5.8	5.8	5.8	5.6	5.9	5.9	5.9	5.6	5.3	5.0	4.8
Gear Ratios: TRN (8): 0.64																	
Speed (MPH):		23.8	27.1	30.5	33.9	37.3	40.7	44.1	47.5	50.9	54.3	57.7	61.1	64.5	67.9	71.3	74.7
Grade (%):		2.3	2.8	3.3	3.8	4.0	4.3	4.3	4.3	4.3	4.3	4.3	4.3	4.1	3.9	3.7	3.5

Engine RPM:	700	800	900	1000	1100	1200	1300	1400	1500	1600	1700	1800	1900	2000	2100	2200
Gross Torque:	555	630	710	790	825	860	859	859	859	859	859	859	829	788	750	716
Net Torque:	478	552	630	708	743	777	778	780	781	782	783	784	757	719	685	654
Net HP:	64	84	108	135	156	178	193	208	223	238	253	269	274	274	274	274



ORDER ENTRY # _____

QUOTATION
REF: STATE OF NH
BID# 125-26

6 ENTERPRISE DRIVE
LONDONDERRY, NH-03053
PHONE: 603-669-2250
FAX: 603-669-0501

P.O. # _____

QUOTE / ORDER # SC04074

DATE: 4/22/26

CUSTOMER: NEW ENGLAND KENWORTH-CONCORD
CONTACT: JUSTIN BARRIAULT
ADDRESS: 24 HALL STREET
CONCORD, NH 03301
PHONE: 603-226-2000
EMAIL: JUSTIN.BARRIAULT@NEWENGLANDKW.COM
BODY SR. # _____ HOIST SR.# _____

TRUCK INFO:
VIN# :
YEAR: 2027
MAKE: KENWORTH
MODEL: 33K GVW
CA/CT: 120"
TRANS.
COLOR: **BLACK.**

"TAFCO" - PLATFORM BODY "STANDARD" 16' LENGTH X 96" WIDTH

2" X 6" T & G - WOOD FLOOR
6 1/4" 10 GAUGE OUTER RAIL
10 GAUGE CROSSMEMBERS - 16" ON CENTER
6" STRUCTURAL CHANNEL LONG SILLS
LIGHT KIT - FMVSS - 108 (LED)
PAINTED STANDARD BLACK

_____ NOT INSTALLED \$ 7,250.00
_____ INSTALLATION \$ 1,900.00

(SET OF F & R MUD FLAPS/ BACK-UP ALARM/ ICC BUMPER/ LIGHTS HOOKUP/ PAINT BLACK)

OPTIONS:

SHOP BUILT HEAD BOARD ----- \$ 1,350.00
 PAIR OF STROBES IN REAR/PAIR OF STROBES IN HEAD BOARD ----- \$ 800.00

TOTAL \$ 11,300.00 EACH
X2 TRUCKS

I HAVE READ AND APPROVED THE ABOVE QUOTATION AND
HEREBY AUTHORIZE YOU TO COMPLETE THE WORK.

CUSTOMER SIGNATURE: _____ **DATE:** _____

NOTE: PAYMENT DUE IN FULL UPON DELIVERY. NO CREDIT CARDS ACCEPTED.

QUOTATION IS VOID AFTER 30 DAYS. QUOTED BY: SCOTT COVATIS



NEW ENGLAND KENWORTH - CONCORD (Y150)
 24 HALL STREET
 CONCORD, New Hampshire 03301

STATE OF NEW HAMPSHIRE
 29 HAZEN DR
 CONCORD, New Hampshire 03302
 United States of America

Justin Barriault
 Cell Phone: 603-581-9085
 Office Phone: 603-226-2000
 Email: justin.barriault@newenglandkw.com

LINCOLN ADAMS
 Email: lincoln.j.adams@das.nh.gov

Vehicle Summary

	Unit		Chassis
Model:	T380 Series Conventional	Fr Axle Load (lbs):	12000
Type:	Full Truck	Rr Axle Load (lbs):	21000
Description 1:	20ft flat bed	G.V.W.R. (lbs):	33000
Description 2:		G.C.W. (lbs):	33000
	Application	Road Conditions:	
Intended Serv.:	Local Pickup & Delivery: Vehicles which	Class A (Highway)	90
Commodity:	General Freight	Class B (Hwy/Mtn)	10
	Body	Class C (Off-Hwy)	0
Type:	Van	Class D (Off-Road)	0
Length (ft):	18	Maximum Grade:	6
Height (ft):	12	Wheelbase (in):	226
Max Laden Weight (lbs):	4000	Overhang (in):	80
	Trailer	Fr Axle to BOC (in):	69.5
No. of Trailer Axles:	0	Cab to Axle (in):	156.5
Type:		Cab to EOF (in):	236.5
Length (ft):	0	Overall Comb. Length (in):	346
Height (ft):	0	Special Req.	
Kingpin Inset (in):	0	U.S. Domestic Registry, 50-state.	
Corner Radius (in):	0		
	Restrictions		
Length (ft):	75		
Width (in):	102		
Height (ft):	13.5		

Approved by: _____

Date: _____

Note: All sales are F.O.B. designated plant of manufacture.

Price Level: January 1, 2026

100% Complete

Date: April 22, 2026

Deal: 20ft flat bed

Quote Number: QUO-1152400-B4N3R6

Printed On: 4/22/2026 3:11:30 PM



Sales Code	Std/Opt	Description	Weight
Model			
0000380	S	T380 Series Conventional	9,930
0070086	S	T380 Aero Hood	0
0072000	O	Chassis Operation Will Not Incl. Stationary application. Stationary operation is defined as running the engine under load while stationary at a substantial fraction of engine gross horsepower (60% or greater) for an extended period of time (longer than 5 - 10 minutes).	0
0080101	O	CARB Low NOX Omnibus Registration Guidelines Dealer/Customer acknowledges that this vehicle is NOT intended for registration or domicile/primary use in the State of California.	0
0080314	O	EPA Clean Idle Label - PACCAR PX Engines	0
0090143	O	T380 Automatic	0
0098429	O	State of Registry: New Hampshire	0
Engine & Equipment			
0130219	O	PACCAR PX-9 300 300@1850 860@1200, 2024 With Turbo Exhaust Brake (VGT Brake) N09420 C333 0.....Reserve Speed Limit Offset (N09380 C334 0.....Maximum Cycle Distance (C334 N09360 C400 252...Reserve Speed Function Reset N09200 C399 100...Standard Maximum Speed Limit N09400 C401 10....Maximum Active Distance (C40 N09220 C402 0.....Expiration Distance (C402) N09540 C395 0.....Expiration Distance (C395) N09260 C121 70....Max Vehicle Speed in Top Gea N09440 C234 NO....Engine Protection Shtdwn N09460 C231 NO....Gear Down Protection N09580 C133 5.....Idle Shtdwn Time N09680 C233 NO....Idle Shtdwn Override N09480 C132 1400..Max PTO Speed N09300 C128 70....Max Cruise Control Speed N09500 C239 NO....Cruise Control Auto Resume N09520 C238 NO....Auto Engine Brake in Cruise N09780 C190 80....High Ambient Temperature Thr N09740 C188 40....Low Ambient Temperature Thre N09760 C189 60....Intermediate Ambient Tempera N09720 C382 YES...Enable Hot Ambient Automatic N09600 C396 YES...Enable Impending Shutdown Wa N09620 C397 60....Timer For Impending Shutdown N09640 C206 35....Engine Load Threshold N09560 C225 NO....Enable Idle Shutdown Park Br	694
1000046	O	EPA Emissions Compliant Engine	0

Price Level: January 1, 2026

100% Complete

Date: April 22, 2026

Deal: 20ft flat bed

Quote Number: QUO-1152400-B4N3R6

Printed On: 4/22/2026 3:11:30 PM



Sales Code	Std/ Opt	Description	Weight
1000151	S	PremierSpec	0
1000243	O	Gearing Analysis: Performance power before economy results.	0
1000257	O	Customer's Typical Operating Spd: 70 MPH	0
1000344	O	EWI Tracking - A2 Engine Module Chassis	0
1000526		RegistrationYear Year of Registration: 2026	0
1000684		Effective VSL Setting NA	0
1000858	O	Engine Idle Shutdown Timer Disabled	0
1000891		Eff EIST NA Expiration Miles Use only with MX and Cummins engines	0
1002060	S	Air Compressor: Cummins 18.7 CFM - Cummins and PX	0
1041399	S	Air Cleaner: MD Composite Engine Mounted	0
1098003	S	Air Restriction Indicator: Mechanical Mounted on Air Cleaner.	0
1105231	O	Fan Hub: Horton On/Off for PX-9 or L9N	0
1121231	S	Cooling Module: 2.1M MD - Aero Hood 1000 Square Inches	0
1247247	O	EXH: Single Can 2024 RH Under with RH Horizontal Tailpipe Below Rail	0
1321102	S	Fuel Filter: PACCAR 2.1M MD for PX-7 or PX-9 Fuel/water separator for 2021 and later engines.	0
1321200	S	Run Aid:None *For Fuel Filter	0
1321300	S	Start Aid:None *For Fuel Filter	0
1504006	O	Block Heater: PACCAR 750 watt 120V for PX-7 and B6.7N. 1000 watt for PX-9 and ISL9 Engines.	2
1816200	O	Alternator: SEG 200 amp, Brush Type Formerly Bosch.	0
1821220	S	Batteries: 2 PACCAR GP31 Threaded Post (700-730) 1400-1460 CCA dual purpose.	0
1836106	O	Mitsubishi 105P55 12V Starter with Cummins and PX PACCAR 12 volt electrical system. W/ centralized power distribution incorporating plug-in style relays. Circuit protection for serviceability, 12- volt light system w/circuit protection circuits number & color coded. Only for Cummins or PX engines.	0
1840065	S	12V Low Voltage Disconnect for Battery Protection	0
1901018	S	Remote PTO/Throttle, 12-Pin, 250K, Back of Cab OR Back of Sleeper, J1939, Remote Control Provision	0

Price Level: January 1, 2026

100% Complete

Date: April 22, 2026

Deal: 20ft flat bed

Quote Number: QUO-1152400-B4N3R6

Printed On: 4/22/2026 3:11:30 PM



KENWORTH

Sales Code	Std/ Opt	Description	Weight
Transmission & Clutch			
2020107	O	Transmission: PACCAR TX-8, Without HSA, 860 LB FT Automatic, 8 Speed, With PTO Provision, 8AP860	0
2406802	O	Driveline: 3 Dana SPL170XL 2 Centerbearing	168
2409942	O	Two Heavy-Duty One-Piece Aluminum Crossmembers This option upgrades existing crossmembers. The cost does not include the centerbearing and bracket. Crossmember locations will be in accordance with Kenworth engineering standards, using the major components specified on the DTPO.	0
2410806	O	Torque Converter: TP1150N for PACCAR TX-8	0
2429094	O	C/I First PACCAR TX-8 PTO 3 O'Clock Position	0
2429358	O	Rear Transmission Support Springs for transmission PTO applications are required to ensure that engine flywheel housings are not overloaded when transmission PTO's are installed.	0
Front Axle & Equipment			
2532108	S	Hendrickson Steertek Front Axle rated 12K Standard Track 3.32 in. drop.	0
2621310	S	Front Brakes: 14.6K Bendix ES S-Cam 16.5x5 in.	0
2659047	O	Front Dustshield: for Drum Brakes: All Front Axles.	6
2690002	S	Front Brake Drums: 14.6K 16.5x5 in. cast.	0
2702500	S	Front Hub: Iron Hub Pilot 14,600 lbs. 11-1/4 in. bolt circle. For use w/ air disc brakes. Consider wheelguards (5850002) w/ aluminum wheels.	0
2741970	S	ConMet PreSet Plus Hub Package; Front Axle.	0
2750001	S	Hubcap: Front Vented.	0
2765001	S	Front Auto Slack Adjuster for Drum Brakes.	0
2863019	O	Front Springs: Taperleaf 12K w/ shock absorbers. With maintenance-free elastomer spring pin bushings.	58
2895223	S	Single Power Steering Gear: 13.2K for Air Brakes.	0
2900058	O	30 mm Front Suspension Spacer Block	0
Rear Axle & Equipment			
3032200	S	Single Meritor MS21-14x4 Rear Axle rated at 21K.	0
3200557	S	Rear Axle Ratio - 5.57.	0

Price Level: January 1, 2026

100% Complete

Date: April 22, 2026

Deal: 20ft flat bed

Quote Number: QUO-1152400-B4N3R6

Printed On: 4/22/2026 3:11:30 PM



Sales Code	Std/ Opt	Description	Weight
3330004	S	Single Rear Brakes 16-1/2x7 in. Bendix ES- extended service S-cam.	0
3392007	S	Single Rear Brake Drums: Cast S-Cam Single For use with 15x8.625", 16.5X7" or 16.5X8.625" brake.	0
3403220	S	Single Rear Hubs: Iron Hub Pilot 26k; 11.25" Bolt circle. Requires "R" series outer ends.	0
3441971	S	ConMet PreSet Plus Hub Package; Single Rear Axle.	0
3465001	S	Single Rear Axle Automatic Slack Adjusters. For use with drum brakes.	0
3485007	S	Spring Brake: 3030 Long Stroke Single 3 in. travel. For drum brakes. Helps keep brakes in adjustment longer.	0
3490047	O	Dustshields for Drum Brakes: All Rear Axles.	11
3495226	S	Bendix 4S/4M Anti-Lock Brake System.	0
3495561	O	Air Operated Park Brake	0
3636421	S	Rear suspension: single Reyco 79KB taperleaf 21K. Medium-duty. Unladen Height: 9 in. Laden Height: 7.5 in. Not rear air disc brake compatible.	0
3836315	O	Bolted Rear Suspension Crossmembers for Reyco 79KB. Replaces medium duty standard.	41
Tires & Wheels			
4079065	O	Front Tires: Bridgestone R273 Ecopia 11R22.5 14PR 14PR	0
4217094	O	Rear Tires: Michelin XDN2 11R22.5 16PR 41.7 in. diameter, drive. 19.5 in. SLR. Code is priced per pair of tires.	60
4899106	S	Tire pressure monitoring system for tire/wheel count: 6.	0
4900004	O	Rear Tire Quantity: 4	0
5042292	S	Front Wheel: Accuride 51455 22.5x8.25 steel Steel Armor[TM] powder coat, hub-pilot mount. 7400lb. maximum rating. 5-hand hole. Air disc brake compatible.	0
5242392	S	Rear Wheel: Accuride 51455 22.5x8.25 steel Steel Armor[TM] powder coat, hub-pilot mount. 7400lb. maximum rating. 5-hand hole. Air disc brake compatible. Code is priced per pair of wheels.	0
5853906	O	Powder Coat White Steel Wheel. Use in Conjunction with front, dual front, rear, spare or lift axle wheel code(s). All wheels on chassis must have same finish color.	0
5900004	O	Rear Wheel/Rim Quantity: 4	0
Frame & Equipment			
6056400	O	Frame Rails: 10-3/4 x 3-1/2 x 3/8in. Steel 285in.	471

Price Level: January 1, 2026

100% Complete

Date: April 22, 2026

Deal: 20ft flat bed

Quote Number: QUO-1152400-B4N3R6

Printed On: 4/22/2026 3:11:30 PM



Sales Code	Std/Opt	Description	Weight
		to 336 in. Truck frame weight is 3.48 lb.-in. per pair of rails. Section modulus is 17.80, RBM is 2,132,000 in.-lbs per rail. Frame rail availability may be restricted based upon application, axle/suspension capacity, fifth wheel setting, or component/dimensional specifications. The results of the engineering review may result in a change to the requested frame rail. If a change is required Kenworth Application Engineering will advise the dealer of the appropriate material specification for a substitute rail.	
6302460	O	Bumper: Tapered Painted Steel Channel. Requires a bumper setting code.	65
6319040	S	40 in. Bumper Setting. Requires a Bumper Code.	0
6321010	S	Front Tow Loops: Two	0
6404420	O	Battery Box: Steel Parallel Module under W/Step, natural aluminum cover. Use with 2 or 3 batteries. Up to 2 air tanks may be mounted to bottom of box. Batteries will be oriented perpendicular to the frame rail in a single row.	9
6409901	O	Battery Box Location: LH Side.	0
6451125	O	DPF/SCR Box Natural End Plates and Natural cover.	0
6490139	O	Heavy-Duty One-PC Aluminum Intermediate/ Fill-In crossmember.	13
6490433	O	Heavy-Duty 5-Piece Rear Cab Support, Hucked assembly. Huck fastened to frame.	15
6742009	S	Square End-of-Frame W/O Crossmember; Non-Towing.	0
Fuel Tanks & Equip			
7144050	O	50 US Gallon D-Shape Rectangular Aluminum BOC fuel tank, replace.	-22
7722173	O	Large DEF Tank, 15 Gallons.	26
7889007	O	Fuel Fill: Center of Tank(s) BOC. Not available on fuel tanks with 3 supports or with full or partial chassis fairings.	0
7889203	O	DEF to Fuel Fill Ratio 2:1 or Greater.	0
7889614	O	DEF Tank Location is LH BOC. For 2.1M Medium-Duty	0
7940050	O	Location: 50 gal fuel tank LH behind cab.	0
Cab & Equipment			
8024311	S	Cab: Stamped Aluminum with Curved Windshield LED markers. Requires separate roof code.	0
8090152	O	Hood: Med Aero w/ Dark Gray Crown In-Mold Color	0
8108011	S	Cab HVAC - Day Cab and 40 in. Sleeper	0

Price Level: January 1, 2026

100% Complete

Date: April 22, 2026

Deal: 20ft flat bed

Quote Number: QUO-1152400-B4N3R6

Printed On: 4/22/2026 3:11:30 PM



KENWORTH

Sales Code	Std/Opt	Description	Weight
		System With Defrost, A/C, and 48,000 BTU/hr Heater. Includes automatic temperature control with one touch defrost operation and dash mounted cab temperature and solar intensity sensors. Pleated fresh air filter and cabin recirculation air filter standard. The Kenworth HVAC system is designed to provide optimal heating and cooling in all operating environments without need for additional insulation. Cab HVAC without sleeper heater AC is available with 40in sleeper.	
8201013	S	Steering Wheel: 18 in. 4-Spoke.	0
8201052	O	Column Mtd TMSN Control W/Retarder Cntrl, RH Side Use with Automated and Automated Manual Transmissions Only	0
8201200	S	Adjustable Telescoping Tilt Steering Column.	0
8205164	O	Dash Switch: 1st Single-Acting Eaton or PACCAR MTD PTO Electric switch, wiring, software, air solenoids, and plumbing are factory-installed to control the 1st Eaton (single-acting) transmission PTO.	0
8208475	O	Two Spare Switches: Wired to Power. BOC Wire termination.	0
8282024	S	Main Instrument Package: 7" Digital Display Cluster. Includes Physical (Analog): Speedometer, Tachometer, Oil Pressure, and Coolant Temp; and Digital: Fuel Level #1, DEF Level, DPF Filter Status, Fuel Economy, Volts Telltale, OAT and Primary Air Pressure, Secondary Air Pressure, and Air Application for air brake trucks.	0
8330591	S	Interior Trim Package: 2.1M MD Gray Foam Backing/Cloth Headliner W/Gray Sunvisor & Seat Color Three Underdash Center Console Cupholders (Two If Allison Transmission Is Selected).	0
8410122	O	Driver Seat: KW Air Seat HB Vinyl w/ Dual Armrests/Susp Cover	0
8480232	O	Rider Seat: KW Toolbox Seat HB Vinyl w/ Dual Armrests/Record Holder/Occupancy Sensor	0
8698970	S	No Radio Or Speakers Selected: No Prewire & No Antenna Wiring. Not w/ Smart Wheel.	0
8700196	S	Turn Signal: Self-Cancelling	0
8700283	S	LH and RH Trip Ledge Rain Deflectors	0
8700601	S	Global Telematics Unit	0
8702232	S	Sensata Tire pressure monitoring system Requires 48991XX tire/wheel count code for sensors.	0
8800372	O	Grabhandle: LH, Exterior, Side of Cab - Ergonomic Grab Handle Mounted To The Left Hand Exterior Of The Cab For Entry and Exit.	3
8800402	S	Dual Cab Interior Grabhandles: A Pillar Mounted Dash Wrap and B Pillar Mounted Grabhandles	0
8832113	S	Kenworth Daylite Door With Standard LH/RH electric door locks and LH/RH electric window controls.	0

Price Level: January 1, 2026

100% Complete

Date: April 22, 2026

Deal: 20ft flat bed

Quote Number: QUO-1152400-B4N3R6

Printed On: 4/22/2026 3:11:30 PM



Sales Code	Std/Opt	Description	Weight
8841411	O	Single Air Horn Under Cab.	0
8850139	S	Look-Down, Pass. Door, Black 11x6	0
8850842	S	Mirror Shell: Dual Aero In-Mold Black	0
8860852	O	Mirror: Dual KW Aero Rear View Motor, heated with Integral CX.	0
8871446	S	Rear Cab Stationary Window 19in x 36in	0
8890101	S	One-Piece Bonded-In Windshield With Curved Glass. Standard.	0
8890881	S	Direct Mount, Rubber Isolated Cab Suspension.	0
8891011	O	Roof: Raised Profile, Stamped Aluminum w/ Additional Head Room & Interior Overhead Storage	0
Lights & Instruments			
9010803	S	Headlamps: Single Halogen Complex Reflector w/ Turn Indicator, Reflector and DRL. Fender Mtd.	0
9020101	S	14-Pin RP170 Body Lighting Connector.	0
9022130	O	Marker Lights: Five Rectangular LED. Chrome housing. For use with raised roof only. Required with exterior sunvisor.	0
9030052	S	LED Stop,Turn,Tail: With Two LED Backup Lights and With An LED License Plate.	0
9090180	O	Backup Alarm: Tail Light Bracket Mounted Variable self-adjusting 82-102 DBA.	0
Air Equipment			
9101218	S	Air Dryer: Bendix AD-HF Puraguard Heated	0
9108001	S	Moisture Ejection Valve W/ Pull Cable Drain.	0
9140020	S	Nylon Air Tubing in Frame & Cab, Excluding Hoses subject to excessive heat or flexing.	0
Extended Warranty			
9200008	O	Base Warranty - PACCAR PX-9 Engine 24 months / 250,000 miles / 402,336 km / 6250 hours.	0
9200022	S	Base Warranty - Standard Service Medium Duty 12 months / Unlimited miles & km	0
9212661	O	TruckTech+ RD - 5YR Sub PACCAR PX Engines	0
9220001	O	Base Warranty: Emissions 5YR/100K MI	0
Miscellaneous			

Price Level: January 1, 2026

100% Complete

Date: April 22, 2026

Deal: 20ft flat bed

Quote Number: QUO-1152400-B4N3R6

Printed On: 4/22/2026 3:11:30 PM



Sales Code	Std/Opt	Description	Weight
9409852	O	GHG Secondary Manufacturer: Does Not Apply	0
9490206	O	Warning Triangle Reflector Kit: Shipped Loose. Kit consists of 3 triangles in plastic carrying case. Not floor mounted.	4
9490404	O	One 5 lb. Dry Chemical Type Fire Extinguisher mounted outboard of driver seat. Class ABC.	11
9491652	S	EMUX Architecture	0
Promotions			
9511431	O	Model Year 2026 Engine	0
Paint			
9700000	O	Paint Color Number(s). N9702 A - Z9990 UNPUBLISHED PAINT N9770 BUMPER N0001 BLACK N9720 FRAME N0001 BLACK	0
9943014	O	Steel Bumper Painted Frame Color	0
9943052	O	Day Cab Pearl Metallic Paint	0
9944820	S	1 - Color Paint - Day Cab Color will be White if no other color is specified.	0
9960003	O	Non-Standard Paint Color. <i>Narr TBD</i>	0
9965510	S	Base Coat/ Clear Coat. The Kenworth Color Selector contains additional instructions, as well as information on Kenworth paint guidelines and surface finish applications. Kenworth is standard with Dupont Imron Elite paint.	0

Special Requirements

- Special Requirement 1 0098025
- Special Requirement 2
- Special Requirement 3
- Special Requirement 4

Fuel Efficiency Score:

Order Comments

Price Level: January 1, 2026
 Deal: 20ft flat bed
 Printed On: 4/22/2026 3:11:30 PM

100% Complete

Date: April 22, 2026
 Quote Number: QUO-1152400-B4N3R6



Total Weight (lbs)

11,565

Any price increase as the result of force majeure, rising costs of components (including but not limited to material shortages) or government tariffs are not included in the quoted price and will be the financial responsibility of the customer.

Prices and Specifications Subject to Change Without Notice.

Unpublished options may require review/approval.

Dimensional and performance data for unpublished options may vary from that displayed in CRM.

PRICING DISCLAIMER

While we make every effort to maintain the web site to preserve pricing accuracy, prices are subject to change without notice. Although the information in this price list is presented in good faith and believed to be correct at the time of printing, we make no representations or warranties as to the completeness or accuracy of this information. We reserve the right to change, delete or otherwise modify the pricing information which is represented herein without any prior notice. We carefully check pricing specifications, but occasionally errors can occur, therefore we reserve the right to change such prices without notice. We disclaim all liability for any errors or omissions in the materials. In no event will we be responsible for any damages of any nature whatsoever from the reliance upon information from these materials. Please check your order prebills to confirm your pricing information

Price Level: January 1, 2026

100% Complete

Date: April 22, 2026

Deal: 20ft flat bed

Quote Number: QUO-1152400-B4N3R6

Printed On: 4/22/2026 3:11:30 PM



Shipping Destinations

Intermediate Destination:

Final Destinations	Quantity
--------------------	----------

Price Level: January 1, 2026
 Deal: 20ft flat bed
 Printed On: 4/22/2026 3:11:30 PM

100% Complete

Date: April 22, 2026
 Quote Number: QUO-1152400-B4N3R6

FRAME RAKE

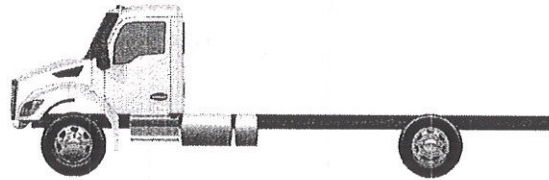

The listed heights should be considered approximations due to variations which may occur in component manufacturing processes, spring set, and the way in which the vehicle is loaded.

Component	Sales Code	Description	Laden	Unladen
Frame	6056400	Frame Rails: 10-3/4 x 3-1/2 x 3/8in. Steel 285in.	10.8	10.8
Front Spring	2863019	Front Springs: Taperleaf 12K w/ shock absorbers.	6.4	8.6
Front Axle Drop 3.5"	2532108	Hendrickson SteerTek Front Axle rated 12K	0.2	0.2
Height Adj.	2900058	30 mm Front Suspension Spacer Block	1.2	1.2
Front Tires	4079065	Front Tires: Bridgestone R27S Ecopia 11R22.5 14PR	19.3	19.8
Front Frame Height			37.8	40.5
Frame	6056400	Frame Rails: 10-3/4 x 3-1/2 x 3/8in. Steel 285in.	10.8	10.8
Subframe	0000000	No sub frame	0	0
Suspension	3636421	Rear suspension: single Reyco 79KB taperleaf 21K.	7.5	9.0
Rear Tires	4217094	Rear Tires: Michelin XDN2 11R22.5 16PR	19.5	20.6
Rear Frame Height			37.8	40.3
Frame Rake			0.0	-0.2
Frame Rake Slope (%)			0.0	-0.1

*These characteristics are considered to be out of standard range:
Laden rake more than 1% of wheelbase from level (positive or negative).*

HORIZONTAL DIMENSIONS

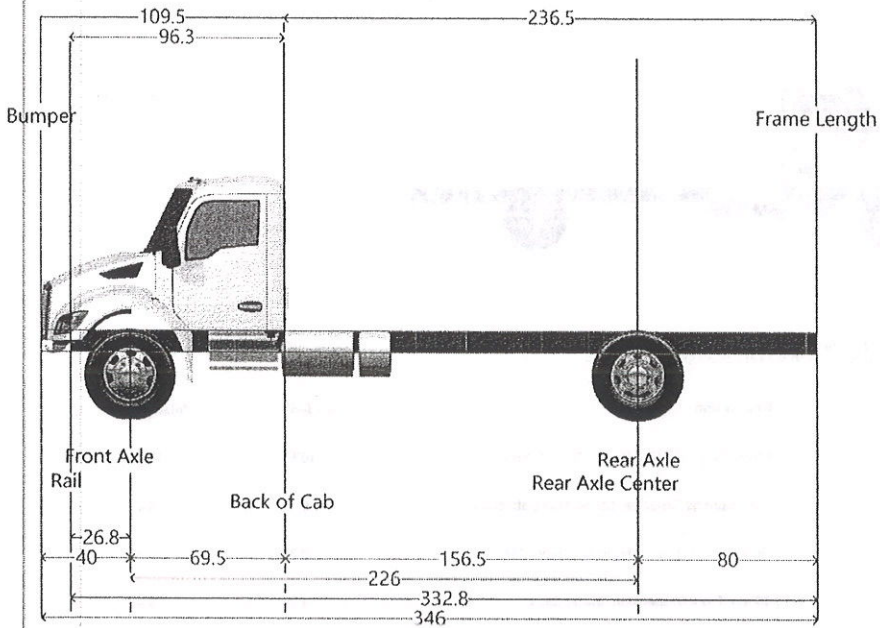

Dimension	Measurement	Start	End
Axle Spacing	0	226	226
Bumper to Back of Cab	109.5	-40	69.5
Bumper to Front Axle	40.0	-40	0
Bumper to Front Frame	13.2	-40	-26.8
Cab to End of Frame	236.5	69.5	306
Cab to Rear Axle	156.5	69.5	226
Effective Bumper to Back Of Cab	109.5	-40	69.5
Frame Length	332.8	-26.8	306
Front Axle to Back of Cab	69.5	0	69.5
Front of Frame to Axle	26.8	-26.8	0
Load Space	236.5	69.5	306
Overall Length	346.0	-40	306
Overhang	80.0	226	306
Pusher Offset #1	0.0	226	226
Pusher Offset #2	0.0	226	226
Pusher Offset #3	0.0	226	226
Tag Offset	0.0	226	226
Wheelbase	226	0	226

VEHICLE WEIGHT RATING

FRONT AXLE COMPONENTS

Component	Sales Code	Description	Ratings
Axle	2532108	Hendrickson SteerteK Front Axle rated 12K	12,000
Springs	2863019	Front Springs: Taperleaf 12K w/ shock absorbers.	12,000
Power Steering	2895223	Single Power Steering Gear: 13.2K for Air Brakes.	13,200
Hubs, Drums	2702500	Front Hub: Iron Hub Pilot 14,600 lbs.	14,600
Brakes	2621310	Front Brakes: 14.6K Bendix ES S-Cam 16.5x5 in.	14,600
Tires	4079065	Front Tires: Bridgestone R273 Ecopia 11R22.5 14PR	12,350
Wheels	5042292	Front Wheel: Accuride 51455 22.5x8.25 steel	

Requested Front (Lbs): 12,000
 Minimum: 0
 Maximum: 12,000

The front axle weight rating cannot exceed 12000

REAR AXLE COMPONENTS

Component	Sales Code	Description	Ratings
Axle	3032200	Single Meritor MS21-14x4 Rear Axle rated at 21K.	21,000
Hubs, Drums	3403220	Single Rear Hubs: Iron Hub Pilot 26k; 11.25" Bolt	26,000
Service Brakes	3330004	Single Rear Brakes 16-1/2x7 in. Bendix ES-	26,000
Spring Brakes	3485007	Spring Brake: 3030 Long Stroke Single 3 in.	26,000
Suspension	3636421	Rear suspension: single Reyco 79KB taperleaf 21K.	21,000
Tires	4217094	Rear Tires: Michelin XDN2 11R22.5 16PR	24,020
Wheels	5242392	Rear Wheel: Accuride 51455 22.5x8.25 steel	29,604

Requested Rear (Lbs): 21,000
 Minimum: 10,000
 Maximum: 21,000

The rear axle weight rating cannot exceed 21000

GROSS COMBINATION WEIGHT RATING

GCWR (lbs)	30,000
Min	26,001
Max	200,000

The Gross Combination Weight Rating cannot exceed 200000

WEIGHT DISTRIBUTION

Model: T380

Actual performance of a specific unit can be affected by your operating conditions. The performance calculations should only be used as a guideline.

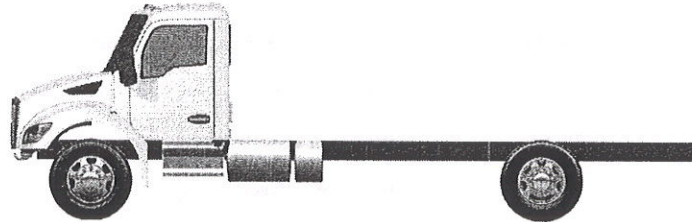

Recommended payload center of gravity to achieve specified ground loads; measured from centerline of drive axles: 44 in. from the centerline of the drive axle(s).

Weight (lbs)	Front	Rear	Total
Chassis	7420	4145	11565
Tools/Driver	292	83	375
Fuel & DEF	297	201	498
Max Payload	3990	16572	20562
Auxiliary Payload	0	0	0
Total	12000	21000	33000
Specify Ground Load	12000	21000	

Auxiliary Payload

Item	Location from FA CL	Weight	Point Description
Load Point #1	0	0	
Load Point #2	0	0	
Load Point #3	0	0	
Component(s)	-	0	Composite Totals

Fifth wheel slide length is **0** inches
 Selected rearmost setting is **0** inches
 Wheelbase measurement: **226** inches
 Overhang measurement: **80** inches

FRAME LAYOUT

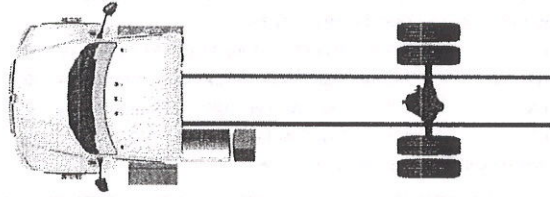

Note: Optional content may be displayed. The order has not yet received an engineering review. The actual arrangement of components may not be exactly as pictured. Additional changes may be made to the layout by Kenworth. Add a Custom Frame Layout code if an exact layout is required.

Selected Options (Wheelbase: 226)

Sales Code	Description	Length	Side
7144050	50 US Gallon D-Shape Rectangular Aluminum BOC	32.7	Left
7722173	Large DEF Tank, 15 Gallons.	14.7	Left
6404420	Battery Box: Steel Parallel Module under W/Step,	31	Left
9101218	Air Dryer: Bendix AD-HF Puraguard Heated	??	??

SPEED & GRADE PERFORMANCE REPORTS

Cruise Report (Engine Fan Off)

Configuration: T380 Series Conventional / Full Truck GCW: 33000
 Quote/DTPO/CO: QUO-1152400-B4N3R6
 Engine: 0130219 PACCAR PX-9 300 300@1850 860@1200, 2024
 Transmission: 2020107 Transmission: PACCAR TX-8, Without HSA, 860 LB FT
 Rear Axle: 3032200 Single Meritor MS21-14x4 Rear Axle rated at 21K.
 Rear Tire: 4217094 Rear Tires: Michelin XDN2 11R22.5 16PR | : 496
 Operating Conditions: 0% Rolling Resistance

Startability	
Transmission Ratio	Maximum Starting Grade
4.89	46.10
3.12	29.41

	700	800	900	1000	1100	1200	1300	1400	1500	1600	1700	1800	1900	2000	2100	2200
Engine RPM:	700	800	900	1000	1100	1200	1300	1400	1500	1600	1700	1800	1900	2000	2100	2200
Gross Torque:	555	630	710	790	825	860	859	859	859	859	859	859	829	788	750	716
Net Torque:	478	552	630	708	743	777	778	780	781	782	783	784	757	719	685	654
Net HP:	64	84	108	135	156	178	193	208	223	238	253	269	274	274	274	274

RAX-Ratio: 5.57

Gear Ratios: TRN (1): 4.89																	
Speed (MPH):		3.1	3.6	4.0	4.4	4.9	5.3	5.8	6.2	6.7	7.1	7.6	8.0	8.4	8.9	9.3	9.8
Grade (%):		23.2	27.2	31.5	35.9	38.0	40.0	40.1	40.2	40.3	40.3	40.4	40.4	38.8	36.6	34.6	32.8
Gear Ratios: TRN (2): 3.12																	
Speed (MPH):		4.9	5.6	6.3	7.0	7.7	8.4	9.0	9.7	10.4	11.1	11.8	12.5	13.2	13.9	14.6	15.3
Grade (%):		14.3	16.7	19.2	21.8	23.0	24.1	24.2	24.2	24.3	24.3	24.3	24.4	23.4	22.2	21.0	20.0
Gear Ratios: TRN (3): 2.03																	
Speed (MPH):		7.5	8.6	9.6	10.7	11.8	12.8	13.9	15.0	16.0	17.1	18.2	19.3	20.3	21.4	22.5	23.5
Grade (%):		9.0	10.5	12.1	13.7	14.5	15.2	15.2	15.2	15.3	15.3	15.3	15.3	14.6	14.0	13.3	12.6
Gear Ratios: TRN (4): 1.64																	
Speed (MPH):		9.3	10.6	11.9	13.2	14.6	15.9	17.2	18.5	19.9	21.2	22.5	23.8	25.2	26.5	27.8	29.1
Grade (%):		7.1	8.4	9.6	10.9	11.5	12.1	12.1	12.1	12.1	12.2	12.2	12.2	11.7	11.1	10.5	10.0
Gear Ratios: TRN (5): 1.25																	
Speed (MPH):		12.2	13.9	15.6	17.4	19.1	20.8	22.6	24.3	26.1	27.8	29.5	31.3	33.0	34.7	36.5	38.2
Grade (%):		5.3	6.2	7.2	8.1	8.6	9.0	9.0	9.0	9.1	9.1	9.1	9.1	8.8	8.3	7.9	7.5
Gear Ratios: TRN (6): 1																	
Speed (MPH):		15.2	17.4	19.5	21.7	23.9	26.1	28.2	30.4	32.6	34.7	36.9	39.1	41.3	43.4	45.6	47.8
Grade (%):		4.1	4.8	5.6	6.4	6.7	7.1	7.1	7.1	7.1	7.1	7.1	7.1	6.9	6.5	6.1	5.8
Gear Ratios: TRN (7): 0.84																	
Speed (MPH):		18.1	20.7	23.3	25.9	28.4	31.0	33.6	36.2	38.8	41.4	44.0	46.5	49.1	51.7	54.3	56.9
Grade (%):		3.3	3.9	4.6	5.2	5.5	5.8	5.8	5.8	5.8	5.9	5.9	5.9	5.6	5.3	5.0	4.8
Gear Ratios: TRN (8): 0.64																	
Speed (MPH):		23.8	27.1	30.5	33.9	37.3	40.7	44.1	47.5	50.9	54.3	57.7	61.1	64.5	67.9	71.3	74.7
Grade (%):		2.3	2.8	3.3	3.8	4.0	4.3	4.3	4.3	4.3	4.3	4.3	4.3	4.1	3.9	3.7	3.5

	700	800	900	1000	1100	1200	1300	1400	1500	1600	1700	1800	1900	2000	2100	2200
Engine RPM:	700	800	900	1000	1100	1200	1300	1400	1500	1600	1700	1800	1900	2000	2100	2200
Gross Torque:	555	630	710	790	825	860	859	859	859	859	859	859	829	788	750	716
Net Torque:	478	552	630	708	743	777	778	780	781	782	783	784	757	719	685	654
Net HP:	64	84	108	135	156	178	193	208	223	238	253	269	274	274	274	274



Hews Company - Bow
 4 Ryan Road
 Bow NH 03304
 Phone: (603) 226-3252
 www.hewsc.com

Quote

Quote ID: Q83244
 Page 1 of 1

Customer: State of NH - Fish & Game
 11 Hazen Drive
 Concord NH 03301

Contact: LINCOLN ADAMS
Phone: (603) 271-2601
Email: lincoln.j.adams@das.nh.gov

Quote Date: 4/22/2026
Quote Valid Until: 5/22/2026
Salesperson: Brett Merrill
Terms: NET 30
Customer #: 14238

STATE OF NH BID 125-26 | DUE: 4/23/26 | PURCHASING AGENT: LINCOLN ADAMS

- 1- RUGBY VERI-CLASS 20' DUMPING PLATFORM BODY
 - 20'4"x 96" platform - overall dimensions.
 - Length - Overall outside length (Inside pocket measurement : subtract 4")
 - Width - Overall outside dimension (Inside pocket measurement: subtract 4")
 - Wood floor (Douglas Fir / 6" Ship Lap)
 - 9" structural steel longmembers
 - 10 GA. formed crossmembers. (12" O/C)
 - 12 GA. side and front rails.
 - 10 GA. rear rail
 - Reinforced 2x4 stake pockets on 24" centers.
 - Sealed lights in "shock resistant" rubber grommets.
 - Acrylic e-coat primed, black powder coat finish.
 - 52" Steel drop-in headboard with window.
 - Wire harness
 - LED Light Kit
 - * Rear flaps
 - * Install back-up alarm

- 1- RUGBY LR-6620 CONVERSION HOIST
 - Twin 6" Cylinder Scissor hoist
 - Direct PTO mount gear pump
 - NTEA Class G/70

INSTALLED, FOB, BOW, NH. \$ 21,985.00 EACH

NOTES:

- 1. THIS QUOTE ASSUMES DELIVERY OF A SUITABLE CHASSIS WITH A CLEAR MOUNTING ENVELOPE

SALESPERSON: BRETT MERRILL

VIN		Year	Make			Model
Transmission	Engine	GVW	CA	WB	Fleet ID	

Accepted by: _____
 Date / PO#: _____ / _____

Sub Total:	\$21,985.00
FET:	\$0.00
Sales Tax:	\$0.00
Grand Total:	\$21,985.00

Final pricing subject to change based on tariff impacts